



Bioness Inc.

25103 Rye Canyon Loop
Valencia, CA 91355 USA
Telephone: 800.211.9136 or 661.362.4850
Email: info@bioness.com
Website: www.bioness.com



Bioness Europe B.V.

Stationsweg 41
3331 LR Zwijndrecht, The Netherlands
Telephone: +31.78.625.6088
Email: international@nl.bioness.com
Website: www.bioness.com

Rx Only



©2021 Bioness Inc.

612-00624-001 Rev. M
01/2021



MEDICAL EQUIPMENT
AS TO ELECTRICAL SHOCK, FIRE AND
MECHANICAL HAZARDS ONLY IN
ACCORDANCE WITH STANDARDS:
ANSI/AAMI ES60601-1 (2005) + AMD (2012)
CAN/CSA-C22.2 No. 60601-1 (2008) + (2014)
E359825

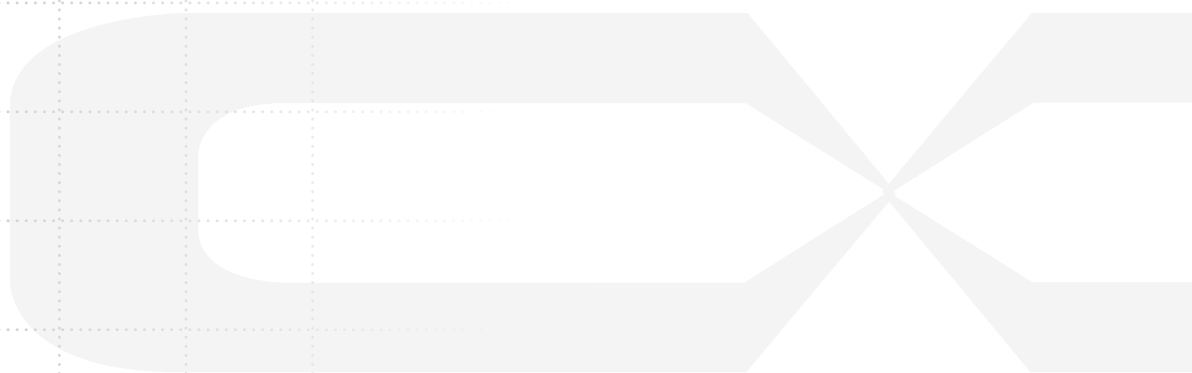

vector
ELITE

Clinician's Guide



Vector Clinician's Guide Copyright

©2021 by Bioness Inc.

All Rights Reserved

No part of this publication may be reproduced, transmitted, transcribed, stored in a retrieval system or translated into any language or any computer language, in any form or by any third party, without the prior written permission of Bioness Inc.

Trademarks

Vector Gait & Safety System[®], Bioness, the Bioness Logo[®] are trademarks of Bioness Inc. in the United States or other countries. | www.bioness.com | **Rx Only**

Bioness Patents

This product is covered by one or more US and international patents. Additional patents pending. For more information on patents visit Bioness website at: <https://www.bioness.com/Patents.php>

Disclaimer

Bioness Inc. shall not be liable for any injury or damage suffered by any person, either directly or indirectly, as a result of the unauthorized use or repair of Bioness Inc. products. Bioness does not accept any responsibility for any damage caused to its products, either directly or indirectly, as a result of use and/or repair by unauthorized personnel.

Environmental Policy



Service personnel are advised that when changing any part of the Vector Elite System, care should be taken to dispose of those parts in the correct manner; where applicable, parts should be recycled. When the life cycle of the Vector Elite System has been completed, the product should be discarded according to the laws and regulations of the local authority. For more detailed information regarding these recommended procedures, please contact Bioness Inc. Bioness Inc is committed to continuously seeking and implementing the best possible manufacturing procedures and servicing routines.



Bioness Inc.

25103 Rye Canyon Loop
Valencia, CA 91355 USA
Telephone: 800.211.9136 or 661.362.4850
Website: www.bioness.com



Bioness Europe B.V.

Stationsweg 41
3331 LR Zwijndrecht, The Netherlands
Telephone: +31.78.625.6088
Email: international@nl.bioness.com
Website: www.bioness.com

List of Symbols















	Warning
	Caution
	Consult Instructions for Use
	Re-Order Number
	Manufacturer
	Serial Number
	Medical Device
	European Authorized Representative
	Temperature Limitation
	Humidity Limitation
	Atmospheric Pressure Limitation
	This product must not be disposed of with other household waste
	Keep Dry
	BF Applied Part
	Complies with the European Union Medical Device Directive

Table of Contents

Chapter 1: Introduction	1
Introduction of Vector Gait & Safety System	1
Device Description	1
<i>Mechanical Track and Power Rail</i>	<i>1</i>
<i>Power Supply Box</i>	<i>2</i>
<i>Vector Elite Trolley</i>	<i>2</i>
<i>Spreader Bar</i>	<i>2</i>
<i>Patient Harness</i>	<i>2</i>
<i>PC</i>	<i>2</i>
<i>Remote Control</i>	<i>2</i>
Chapter 2: Safety Information	3
Intended Use	3
Contraindications	3
Precautions	3
Warnings	4
Environmental Conditions that Affect Use	5
Electromagnetic Emissions	5
Warnings	5
Incident Reporting	6
Chapter 3: Patient Harness Fitting Instructions	7
Selecting a Harness Size	7
Donning a Patient Harness	7
Chapter 4: Starting the Vector Elite System and Software	9
Turning the System On and Off	9
Launching the Vector Gait & Safety Software	10
<i>Main Menu Screen</i>	<i>10</i>
<i>Logout Button</i>	<i>12</i>
<i>Exit Button</i>	<i>12</i>
Chapter 5: Patient Training Menu	13
Creating a New Patient Account	13
Opening an Existing Patient Account	14
Introduction to the Training Session Screen	15
<i>Manual Controls</i>	<i>16</i>
<i>Training Controls</i>	<i>17</i>
Treadmill Controls	21
Outcome Measures	21

Session Status Section	21
Emergency Stop and Emergency Lower Buttons	22
Preparing for a Training Session	22
Attaching a Patient Harness to the Spreader Bar	23
Starting a Training Session	24
<i>Changing Fall Prevention Mode During a Training Session</i>	25
<i>Adjusting the Dynamic Unloading Value During a Training Session</i>	25
<i>Adjusting the Fall Limit Value During a Training Session</i>	25
<i>Changing the Assistance Level During an Active Body Control Session</i>	26
Fall Limit Detection	26
<i>Auto Recovery</i>	27
Stopping a Training Session	27
Session Summary Screen	28
Vector Elite Time-Out Feature	29
Chapter 6: Advanced Training Features	31
Advanced Trolley Tracking	31
<i>Trolley Cue</i>	31
<i>Enabling Posterior & Anterior Cue</i>	32
<i>Enabling Anterior Chase</i>	32
<i>Trolley Range</i>	33
Advanced Body Weight Support	33
<i>Gait Smoothing</i>	33
<i>Ascent Assist</i>	34
<i>Enabling Gait Smoothing</i>	34
<i>Enabling Ascent Assist</i>	35
Treadmill Integration with the Vector Elite Software	35
Connecting the Treadmill to the Vector Elite System	35
Treadmill Controls	37
Chapter 7: Vector Outcome Measures	41
Types of Outcome Measure Tests	41
<i>Timed Up and Go (TUG) Test</i>	41
<i>Walking Tests</i>	41
Preparing for an Outcome Measures Test Run	41
<i>Equipment List</i>	41
<i>Course Setup</i>	42
Starting an Outcome Measures Test Run	42
<i>Timed Up and Go (TUG) Test</i>	43
<i>Walking Tests</i>	46
<i>Adjusting Training Controls During an Outcome Measures Test</i>	48
Chapter 8: Manual Control, Summaries, and Reference Library Menus	49
Manual Control Menu	49

Summaries Menu	51
Reference Library Menu	57
Chapter 9: Vector Elite Remote Control	59
Starting the Vector Elite Remote Control	59
Vector Elite Remote Control	59
<i>Vector Elite Remote Control Software Screens</i>	59
<i>Manual Control Screen</i>	60
<i>Training Controls Screen</i>	60
<i>Status Screen</i>	61
<i>Take Control Screen</i>	61
<i>Treadmill Controls Screen</i>	61
<i>Remote Control Outcome Measures</i>	62
Controlling Device Status	63
Using the Remote Control for a Patient Training Session	65
<i>Adjusting the Dynamic Unloading Value During a Training Session</i>	65
<i>Changing Fall Prevention Mode During a Training Session</i>	66
<i>Adjusting the Fall Limit Value During a Training Session</i>	66
<i>Changing the Assistance Level During an Active Body Control Session</i>	66
<i>Disabling the Fall Limit</i>	67
<i>Fall Prevention</i>	67
<i>Auto Recovery</i>	67
Using the Remote Control with an Integrated Treadmill	68
Using the Remote Control for an Outcome Measures Test	72
<i>TUG Test</i>	72
<i>Walk Test</i>	73
Emergency Stop and Emergency Lower	74
Using the Remote Control to Operate System without Patient Data	74
Advanced Training	74
<i>Intuitive Body Weight Support</i>	75
<i>Trolley Cue</i>	76
Charging the Remote Control	77
Chapter 10: Multi-Trolley Sync Feature	79
Sync Menu.....	79
Chapter 11: Vector Elite Software Administrator Menu	81
Accessing the Administrator Menu	81
Admin Menu	82
<i>Admin Menu Options</i>	82
<i>Patient Database Menu</i>	82
<i>Edit a Patient Account</i>	83
<i>Create a New Patient Account</i>	83
<i>Delete a Patient Account</i>	83

<i>Import a Patient Account</i>	84
<i>Add Users Menu</i>	85
<i>Backup and Restore Database Menu</i>	86
<i>Troubleshooting Menu</i>	88
<i>System Settings Menu</i>	88
<i>Tracking Responsiveness</i>	88
Chapter 12: Troubleshooting	91
Troubleshooting WiFi Connection Issues	91
<i>Troubleshooting PC WiFi Connection Issues</i>	91
<i>Troubleshooting Remote Control WiFi Connection Issues</i>	91
Elite Trolley Light Indicators	92
Troubleshooting Error Screens	92
Chapter 13: Service and Maintenance	95
Cleaning the Patient Harness.....	96
PC Disk Storage Space Maintenance	96
Chapter 14: Technical Specifications	97
Chapter 15: Electromagnetic Compatibility (EMC) Information	99
Chapter 16: Network Safety, Security, and Privacy	103

Introduction

Introduction of Vector Gait & Safety System

The Vector Elite (model number VEC-1000) is a body weight support system designed to accelerate physical rehabilitation of patients with severe gait or balance impairment. The system provides dynamic body weight support and trolley tracking, enabling the patient to practice gait and balance training by offloading a portion of their body weight. A computer-controlled motor keeps the trolley at a desired location relative to the patient, and a separate computer-controlled motor ensures that the rope tension is kept at a desired value. The patient may walk along a predetermined path or on a treadmill. The system receives control signals through an encrypted WiFi signal from a PC or remote control. The Vector Elite System is designed to be used in a hospital/professional healthcare facility.

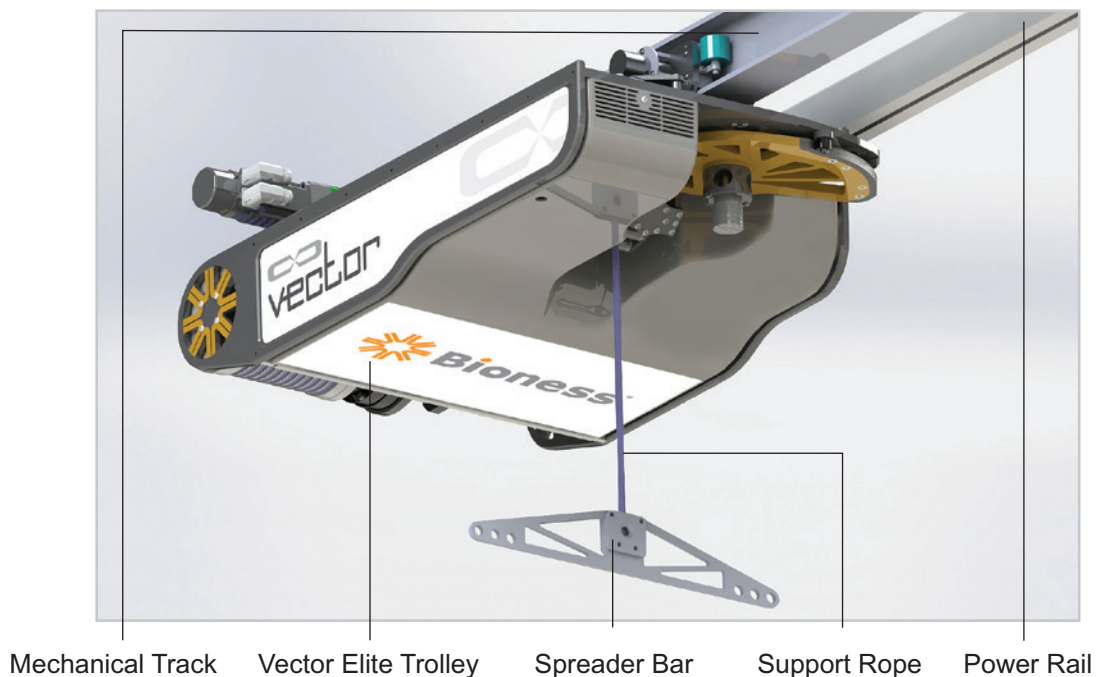

Figure 1-1: Vector Elite Trolley

Device Description

The Vector Elite system consists of a mechanical track, power rail, power supply box, motorized trolley with rope, spreader bar, patient harness, PC computer with proprietary software, and an optional remote control.

Mechanical Track and Power Rail

The mechanical track is mounted overhead, typically attached to a support beam, floor or truss, and the trolley runs along the track. The mechanical track defines the horizontal aspect of the walking path of the patient. The track includes straight and/or curved portions that form either a closed loop track configuration or an open track configuration.

An open track configuration utilizes an End of Track Bumper on each track end to ensure the trolley is safely stopped. The power rail is attached to the overhead mechanical track and delivers electricity to the Vector Elite trolley.

Power Supply Box

The power supply box is mounted to a wall and plugs into a dedicated electrical outlet. It converts electrical power from the building to a predetermined power level, which is supplied to the trolley through the power rail. The power supply box also contains an electrical isolation transformer, as a safety feature of the system.

Vector Elite Trolley

The Vector Elite trolley consists of two motors and a rope that attaches to the spreader bar. A computer-controlled motor keeps the trolley at a desired location relative to the patient, and a separate computer-controlled motor ensures that the rope tension is kept at a desired value.

Spreader Bar

The spreader bar connects a patient harness to the Support Rope at two points. On each side of the spreader bar there are three holes built to accommodate patients of different sizes.

Patient Harness

The patient harness secures a patient during a therapy session. The patient harness comes in a variety of different sizes and attaches to the spreader bar.

PC

The touch-screen PC contains the software that controls the Vector Elite system and manages the secure patient database. The Vector Gait & Safety System software is password-protected and communicates with the trolley through an encrypted WiFi signal.

Remote Control

The optional remote control may be used to control the System once a training session has begun. This accessory is not necessary to operate the Vector Elite system. The remote control uses an Android operating system with a Vector Gait & Safety System application and communicates with the trolley through an encrypted WiFi signal.

Be sure to review this guide, including all safety information, before using the Vector Elite system. If you have questions contact Bioness at 800.211.9136, Option 3 (in the United States) or your local distributor (outside of the United States). You can also visit the Bioness website at: www.bioness.com.

 **Caution:** Do not use the Vector Elite system until you have been properly trained by a Bioness representative.

Safety Information

Intended Use

The Vector Elite system is a body weight support system designed to accelerate physical rehabilitation of patients with severe gait and/or balance impairment. The system unloads a programmed amount of weight to enable the patient to practice walking with less than his or her full body weight.

Contraindications

Prior to use, all patients need to be deemed medically stable and appropriate by a trained healthcare professional. Patients with the following diagnoses, symptoms, or findings should not use the Vector Elite system:

- Body weight more than 500 lbs. (227 kgs.)
- Unstable fractures
- Halo neck supports
- Uncontrolled hypertension
- Uncontrolled diabetes
- Severe osteoporosis

Precautions

- Pulling down on the spreader bar and then letting go could cause injury; use with caution.
- For correct usage, ensure that the patient harness connection to the spreader bar is not too narrow or too wide.
- Use care when assisting patients into/out of a harness so they do not get tangled and fall.
- Follow instructions carefully to prevent pulling or jerking the patient in the equipment.
- Carefully measure and fit the harness to the patient. Incorrect sizing may cause discomfort and/or injury.
- Use care when attaching the patient harness to the spreader bar. If not attached correctly, the patient may fall.
- When using a multi-trolley configured system on the same track, leave a safe distance between patients to prevent collision injury or injury from a patient fall.
- In a multi-trolley configured system, while using the manual controls, avoid driving the Vector Elite trolley into the other trolley on the same track.
- Before starting a training session with a multi-trolley configured system, make sure the correct computer and remote control are being used with the correct Vector Elite trolley. The incorrect computer or remote control will not operate the trolley. The remote control and computer are configured to only operate the trolley with which they are paired.

- Ensure that the handheld is operating and communicating with the appropriate computer before starting a training session.

Warnings

- Incorrect patient data entry or incorrect patient retrieval may cause the patient to fall and/or serious injury.
- Do not place a patient that weighs less than 30 lbs. (13 kgs.) or more than 500 lbs. (227 kgs.) in the Vector Gait & Safety System.
- Do not exceed recommended weight limits or otherwise misuse the equipment. The equipment can dislocate and fall causing serious injury.
- Do not lift the patient too high or have the patient ascend/descend high stairs where they might be injured from the trolley.
- Do not touch the motorized Vector Elite trolley during a training session. The trolley contains moving parts that could cause injury if touched.
- In an emergency such as an electrical outage, stop exercise immediately to avoid injury and turn off the power switch located on the power station.
- Do not attempt to service or repair the Vector Elite system or electrocution may occur.
- Modifying the Vector Elite system equipment voids the warranty.
- Do not use the Vector Elite system if maintenance is required; serious injury may occur.
- In the event of power failure, carefully remove patient from the harness and step away from the equipment.
- Do not use equipment if the Vector Elite trolley has become wet (e.g., from sprinklers) as there is a risk of electrocution. Servicing is required before the equipment may be used.
- To avoid risk of electric shock, this equipment must only be connected to a supply mains with protective earth.
- The Vector Elite system is not intended for patient transport. Using the system as a transport could cause serious patient injury.
- Manually moving the trolley along the track by pulling on the Support Rope, could damage the Vector Elite system.
- The Vector Gait & Safety System may only be operated by a trained health care professional.
- The use of accessories not specified by the manufacturer may result in injury and/or increased emissions, or decreased immunity of the equipment, affecting its performance.
- There is a possibility of electromagnetic interference with other devices. When there is suspicion of possible EMC interference to the Vector Gait & Safety System, it is recommended to shut down the electrical devices nearby, one by one, to locate the possible interference source.
- Due to potential confusion about which computer is being used with which patient, a clinician should not operate multiple computers at the same time.
- The Vector PC and Remote Control network configurations should not be modified without direction from Bioness Support, including changing network connection or connection to the

Internet. Modification of the network can void the warranty and may affect equipment performance.

- The Vector PC and Remote Control should be used by trained healthcare professionals only outside of the patient environment and are to be used for operation of the Vector system only. Any modification to the operating systems, software, or configuration can void the warranty and may affect equipment performance.
- The Vector PC and database are secured using a username and password. Each user of the Vector system should keep the password secure and ensure that the system is not left unattended.

Environmental Conditions that Affect Use

Radio Frequency (RF) Communication Information

This equipment generates, uses, and can radiate RF energy and, if not installed and used in accordance with the instructions, may cause harmful interference to radio communications. However, there is no guarantee that interference will not occur in a particular installation. If this equipment does cause harmful interference to radio or television reception, which can be determined by turning the equipment off and on, the user is encouraged to try to correct the interference by one or more of the following measures:

Reorient or relocate the receiving antenna

Increase the separation between the equipment and receiver

Consult the dealer or an experienced radio/TV technician for assistance

The antenna for each transmitter must not be co-located or operating in conjunction with any other antenna or transmitter

Portable and mobile RF communications equipment may affect the Vector Elite System

Electromagnetic Emissions

The Vector Elite System needs special precautions regarding electromagnetic compatibility (EMC). The system needs to be installed and put into service according to the EMC information provided in this manual.

Warnings

- Do not use the Vector Elite System within three feet (1 meter) of shortwave or microwave therapy equipment. Such equipment may produce instability in the dynamic function of the unit.
- Portable RF communications equipment (including peripherals such as antenna cables and external antennas) should be used no closer than 30cm (12 inches) to any part of the Vector Elite System, including cables specified by the manufacturer. Otherwise, degradation of the performance of this equipment could result.
- The Vector Elite System should not be used adjacent with other equipment. If adjacent use is necessary, the equipment or system should be observed to verify normal operation in the configuration in which it will be used.

- The use of accessories, transducers, and cables other than those specified (with the exception of transducers and cables sold by the manufacturer of the Vector Elite System as replacement parts for internal components) may result in increased emissions or decreased immunity of the Vector Elite System.
- The Vector Elite System may be interfered with by other equipment, even if that other equipment complies with CISPR (International Special Committee on Radio Interference, International Electrotechnical Commission) emission requirements.
- The emissions characteristics of this equipment make it suitable for use in industrial areas and hospitals (CISPR 11 class A). If it is used in a residential environment (for which CISPR 11 class B is normally required) this equipment might not offer adequate protection to radio-frequency communication services. The user might need to take mitigation measures, such as relocating or re-orienting the equipment.

Incident Reporting

Any serious incident that has occurred in relation to the device should be reported to the manufacturer and the competent authority of the Member State in which the user and/or patient is established if within the European Union.

Patient Harness Fitting Instructions

The Vector Elite system is used with a patient harness. The sizing chart and fitting instructions in this chapter are for the Maine Anti-Gravity Systems patient harness.

Selecting a Harness Size

It is important to make sure that the proper size harness is selected for a patient to ensure safety and effectiveness while using the Vector Elite system. Refer to Table 3-1 for harness sizing.

Harness Size	Waist Size ¹	Harness Color Code
X-Small	24"-28" (60 cm - 71 cm)	Gray
Small	28"-32" (71 cm - 81 cm)	Yellow
Medium	32"-36" (81 cm - 91 cm)	Red
Double Medium	34"-38" (86 cm - 96 cm)	Purple
Large	36"-40" (91 cm - 101 cm)	Blue
X-Large	40"-44" (101 cm - 111 cm)	Green
2X-Large	44"-48" (111 cm - 121 cm)	White
3X-Large	48"-52" (121 cm - 132 cm)	Orange
4X-Large	52"-56" (132 cm - 142 cm)	Brown
5X-Large	56"-60" (142 cm - 152 cm)	Pink

¹ Waist size is determined by measuring 2 in (5 cm) below the umbilicus (belly button) tightly around the torso.

Table 3-1: Maine Anti-Gravity Systems Patient Harness Sizing Chart

Donning a Patient Harness

 **CAUTION:** Inspect the harness prior to use. Do not use if the harness straps are torn, if there is separation in the harness stitching, or if the Velcro® is unable to adhere. Contact Bioness or your local distributor to order a replacement harness.

1. Detach all Velcro® attachments to open the vest.
2. Make sure the patient is in a secured position.
3. Have the patient put their arms through the shoulder straps to put on the vest. The open side of the vest will face the front.
4. Secure the lower abdominal support first by attaching the Velcro®. Make sure the support is as tight as possible.
5. Secure the upper abdominal support by attaching the Velcro®. Note: This is the middle support with the netting material on the back.
6. Securely attach the top torso support.

7. Tighten side straps on lower abdominal support.
8. Adjust side vertical straps, if necessary.
9. Wrap leg supports around the upper thigh and secure the Velcro®.
10. Adjust side vertical straps attached to the leg supports, if necessary.
11. Adjust shoulder straps to the desired length.

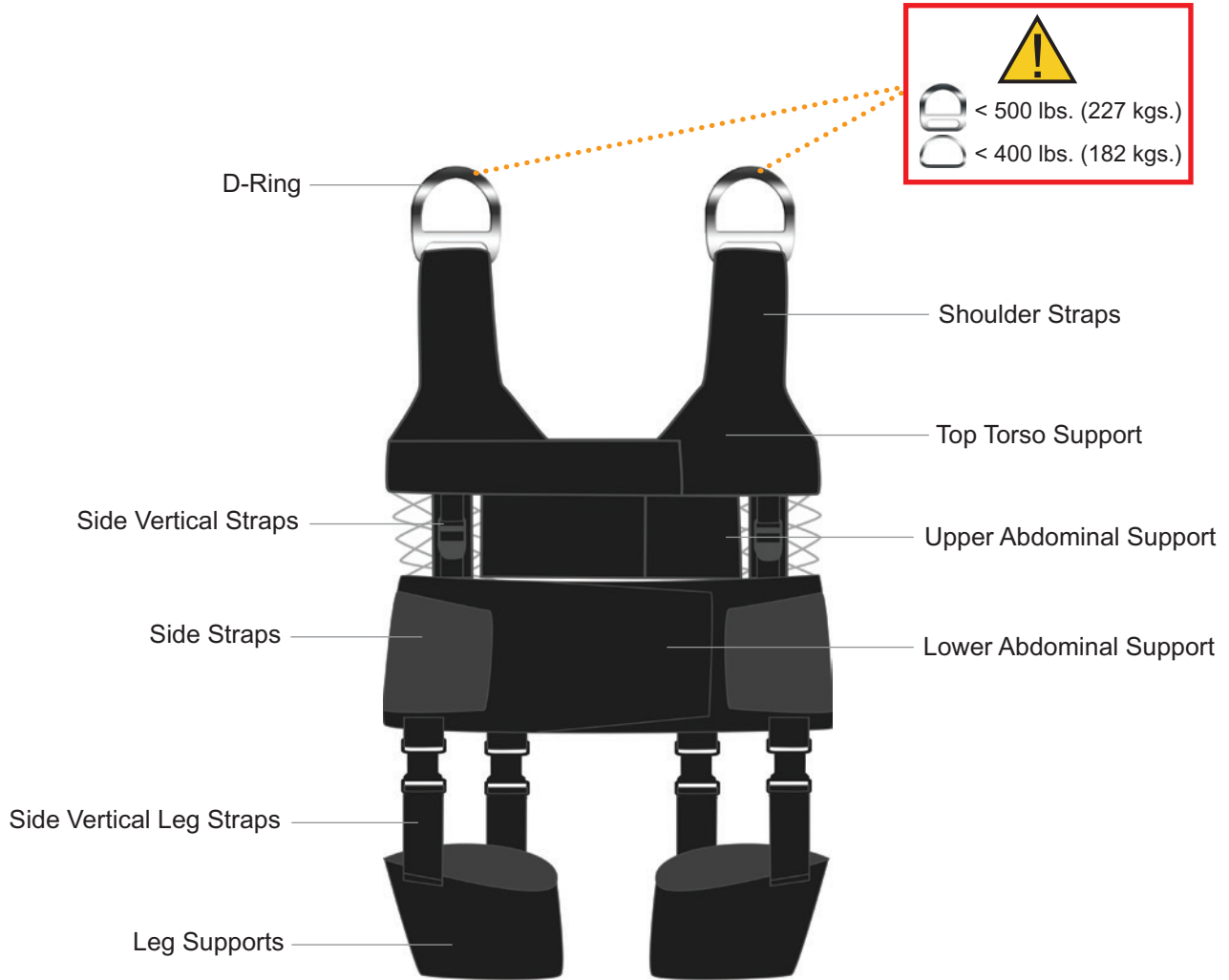

Figure 3-1: Patient Harness Features

Starting the Vector Elite System and Software

Turning the System On and Off

1. Turn the power switch, located on the wall mounted power supply box to the ON position. See Figure 4-1.



Figure 4-1: Location of Power Switch on the two models of Power Supply Boxes

2. The Vector Elite trolley will initialize. After approximately 90 seconds, a green light on the posterior of the trolley body will appear, indicating that the power is on and the system started properly.
3. After the power has been turned on, turn on the touchscreen PC.
4. Touch the middle of the display screen and slide up with finger to reveal the Windows login screen. See Figure 4-2.

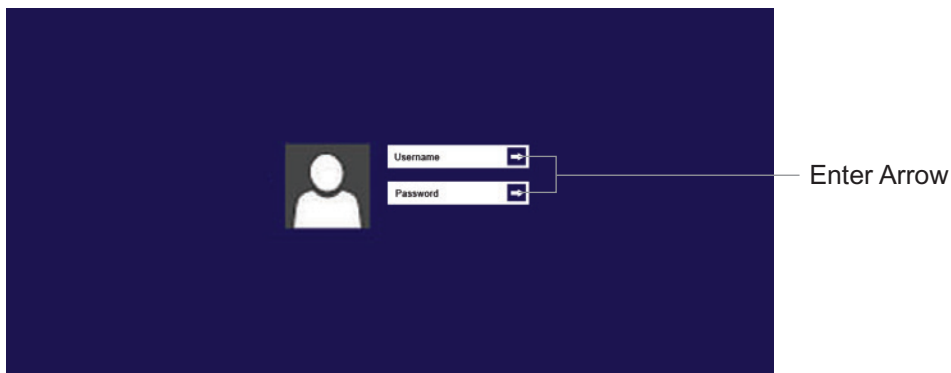

Figure 4-2: Windows Login Screen

5. Use the keyboard to enter in your user name and password. Press the enter arrow button.
6. Press the desktop icon on the touch screen display.

Launching the Vector Gait & Safety Software

1. To launch Vector Elite software click on the Vector Gait & Safety System Icon on the desktop.
2. The login screen will open. Use the keyboard to enter in your user name and password. Press the green arrow button to login. See Figure 4-3.

Note: Login user name will be set up when the administrator creates new user accounts.

3. The Main Menu screen will open. See Figure 4-4.



Figure 4-3: Login Screen

Main Menu Screen

The Vector Elite main menu screen has four menu options for a single-trolley configured system and five menu options for a multi-trolley configured system. The menu options appear as buttons with descriptive icons on the Main Menu Screen. See Figures 4-4 and 4-5.

Main Menu Options, Single Trolley Configured System

- Patient Training menu – This option allows the user to access the patient database, create a new patient account, and start a training session.
- Manual Control menu – This option allows the user to control the Vector Elite trolley manually without needing to select a patient account.
- Summary menu – This option allows the user to view a patient's training history data.
- Reference Library menu – This option allows the user to access training videos, and the Vector Elite Clinician's Guide.

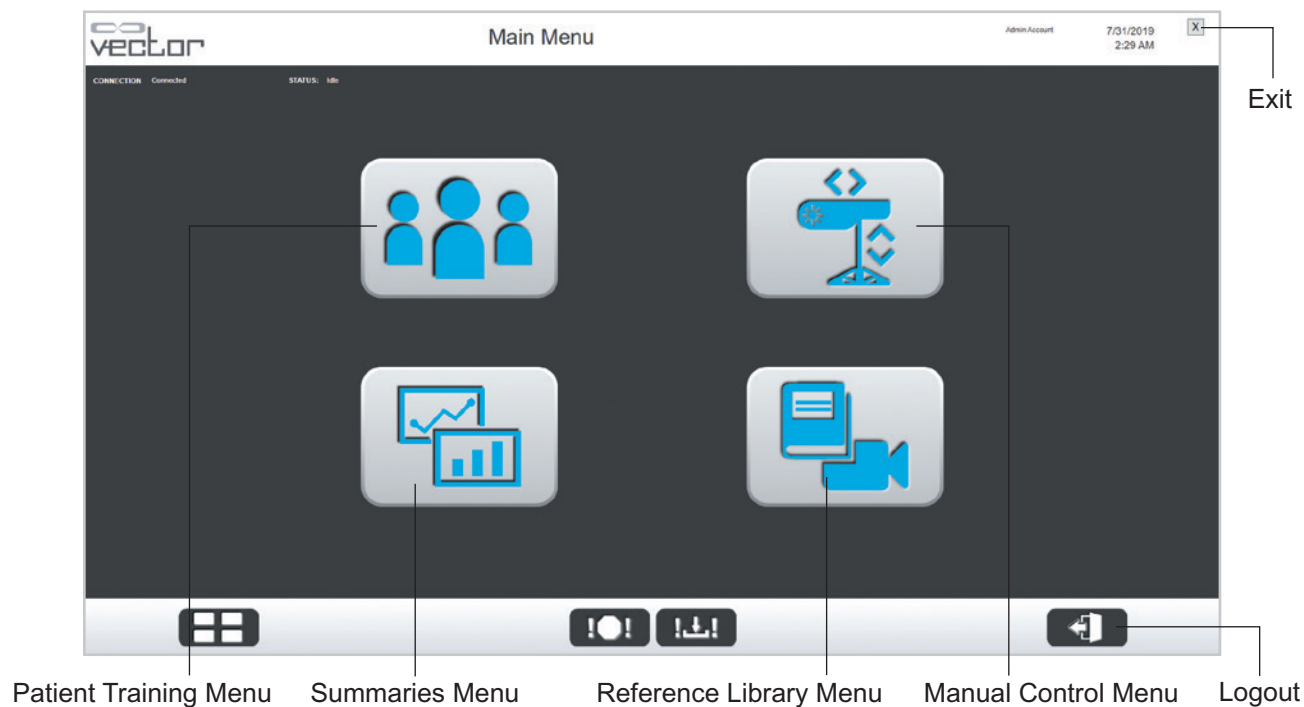

Figure 4-4: Main Menu Screen
(Single Trolley System Configuration, User Level Access)

Main Menu Options, Multi-Trolley Configured System: See Figure 4-5

For a multi-trolley configured system, the Main Menu screen will have all of the same menu options found on the single trolley system (Patient Training, Manual Control, Summaries, and Reference Library menus) plus the additional option listed below.

- Sync Menu – This option allows the user to manually sync the databases. This menu also displays the status of synchronization including timestamp of last successful or failed sync. See the Multi-Trolley Sync feature section of this guide for more information.

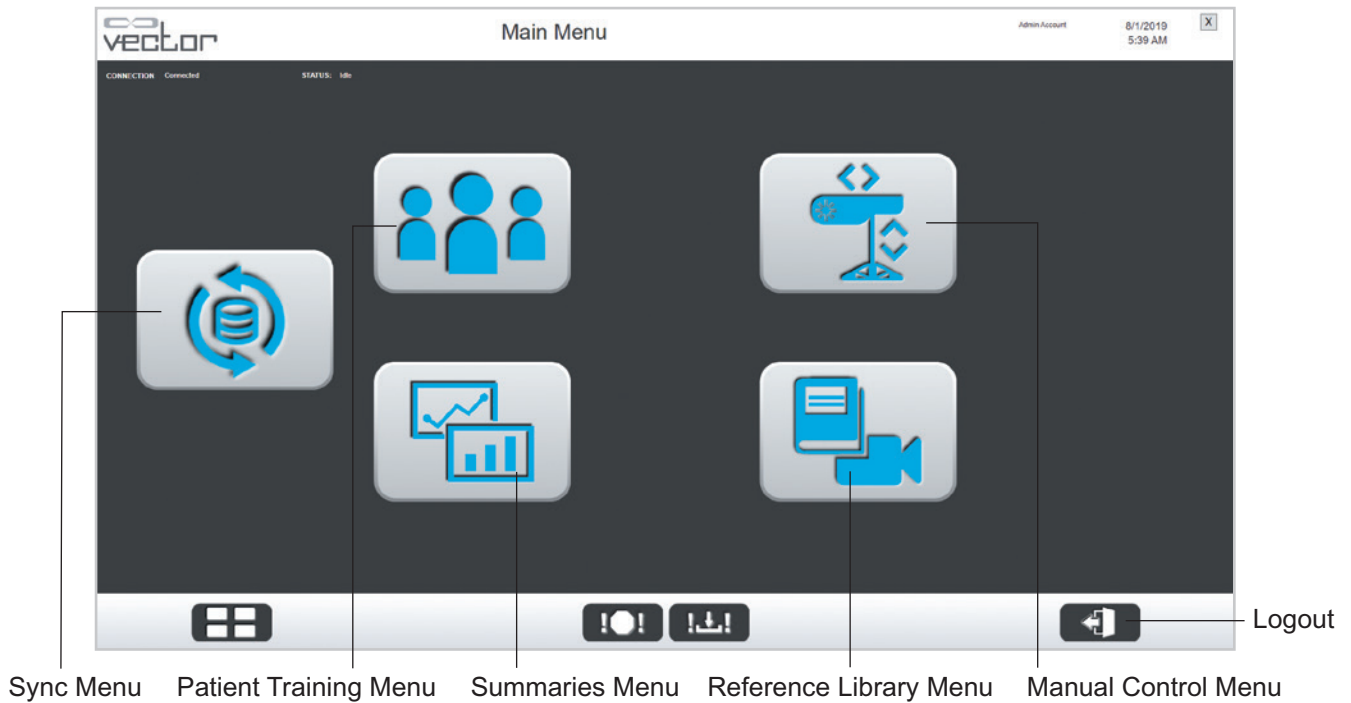

Figure 4-5: Main Menu Screen (Multi-Trolley System Configuration)

Logout Button

The logout button appears in the lower right corner of the display. See Figure 4-4. Pressing the logout button will bring the user back to the application login screen. It is recommended to press the logout button after each therapy session.

Note: Exit out of the Vector Elite software application when not in use.

Exit Button

To exit the Vector Elite software application, press the exit button, located in the upper-right corner of the display. See Figure 4-4. The display screen will return to the desktop.

Patient Training Menu

The Patient Training menu is used to create a new patient account, access the database and start a training session.

⚠ Caution: Incorrect data entry or incorrect retrieval may cause the patient to fall and/or result in serious injury.

Creating a New Patient Account

1. From the Main Menu screen, press the Patient Training Menu button. This opens the Patient Menu screen. See Figure 5-1.
2. Fill in the required patient data fields. Some data fields will have a drop-down menu. See Figure 5-1. Required fields are marked with an asterisk (*). Verify that all information is correct.

Note: The patient ID is permanent and cannot be edited.

3. Press the Save button to save the data and create a new patient account. See Figure 5-1. The entries cannot be saved until all of the required fields are filled.
4. The patient's name will now appear in the Known Patient list. Select patient's name from the list.
5. Press the Start Training button to start the patient training session. Unless a patient is selected, the Start Training button will not appear.

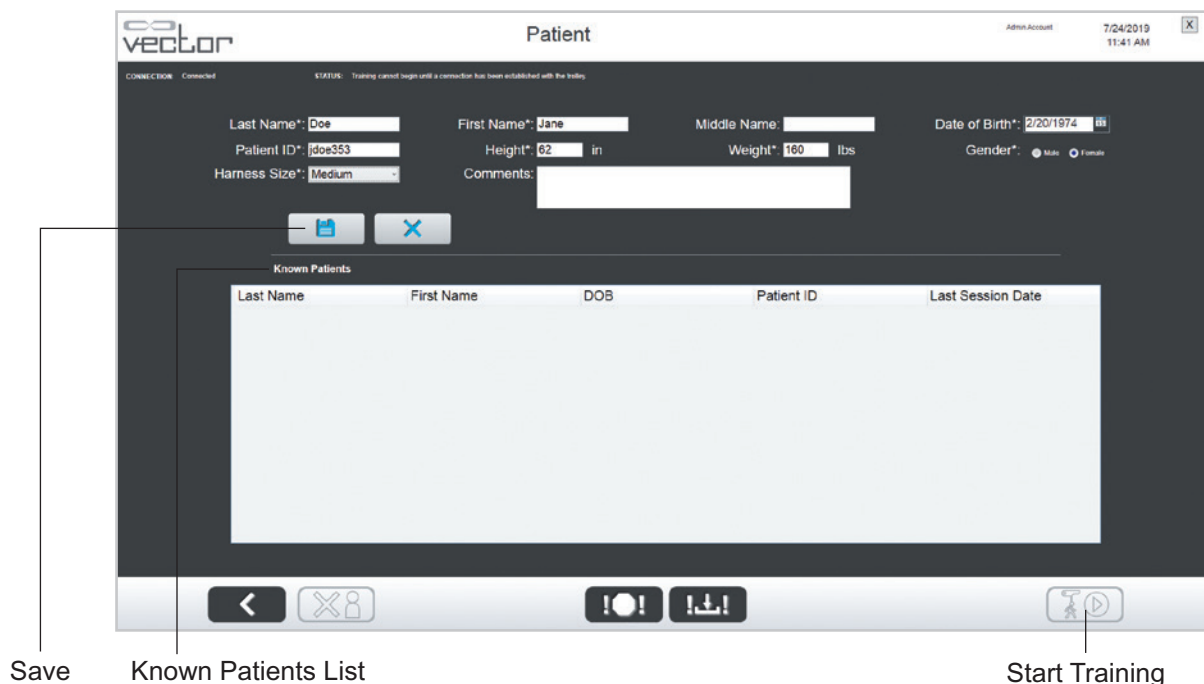

Figure 5-1: Patient Menu Screen

Opening an Existing Patient Account

1. From the Main Menu screen, press the Patient Training Menu button. See Figure 4-4. This will open the Patient Menu screen.
2. The screen will display patients currently in the database under the Known Patients list.
3. Select the desired patient by pressing the row containing the name. Scroll up/down or start typing in the patient's name in the blank fields to filter the database results.
4. Once the patient has been selected, the data fields will auto-fill with the patient's information. Edit the patient's information by pressing the Edit button. Press the Clear button to clear data from all of the field. See Figure 5-2.
5. Press the Start Training button to open the Training Session screen. See Figure 5-2.

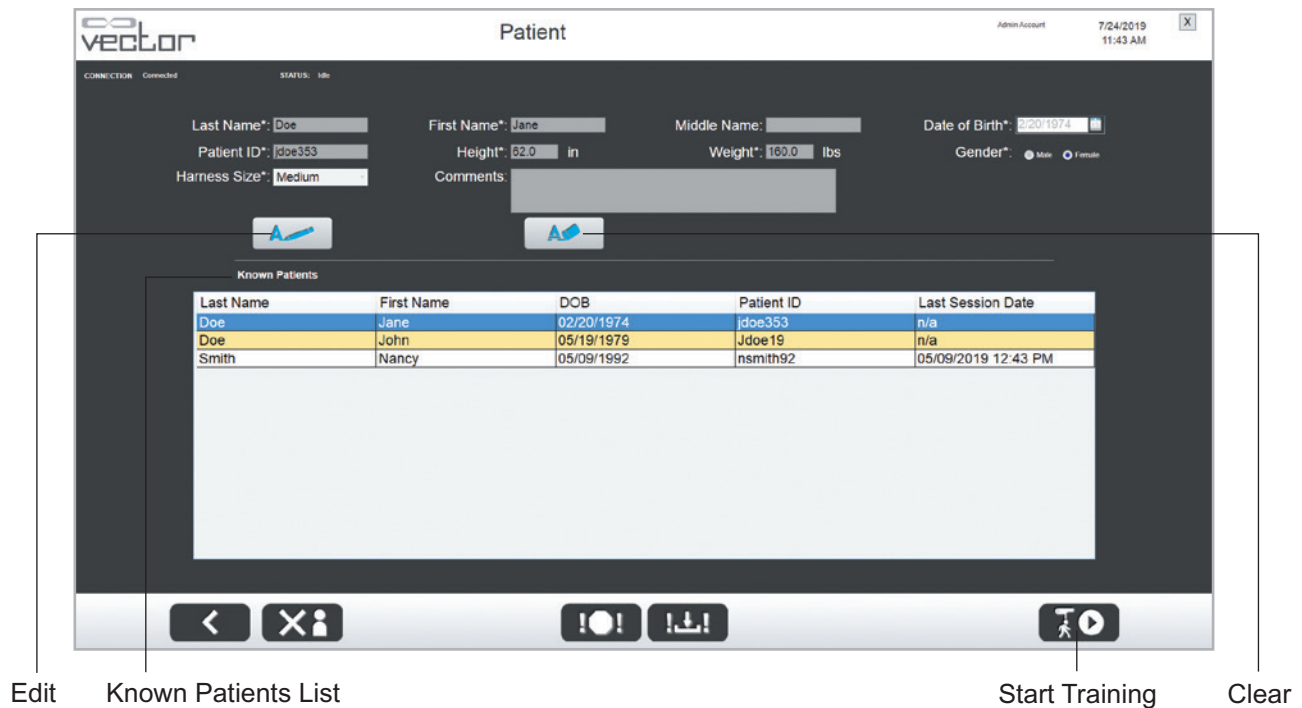

Figure 5-2: Selecting an Existing Patient

Introduction to the Training Session Screen

The Training Session screen is divided into four sections: Manual Controls, Training Controls, Outcome Measures and Session Status. See Figure 5-3. Vector Elite systems may interface with a treadmill. The Treadmill Controls will be displayed by selecting the Treadmill Controls tab. See Figure 5-4.

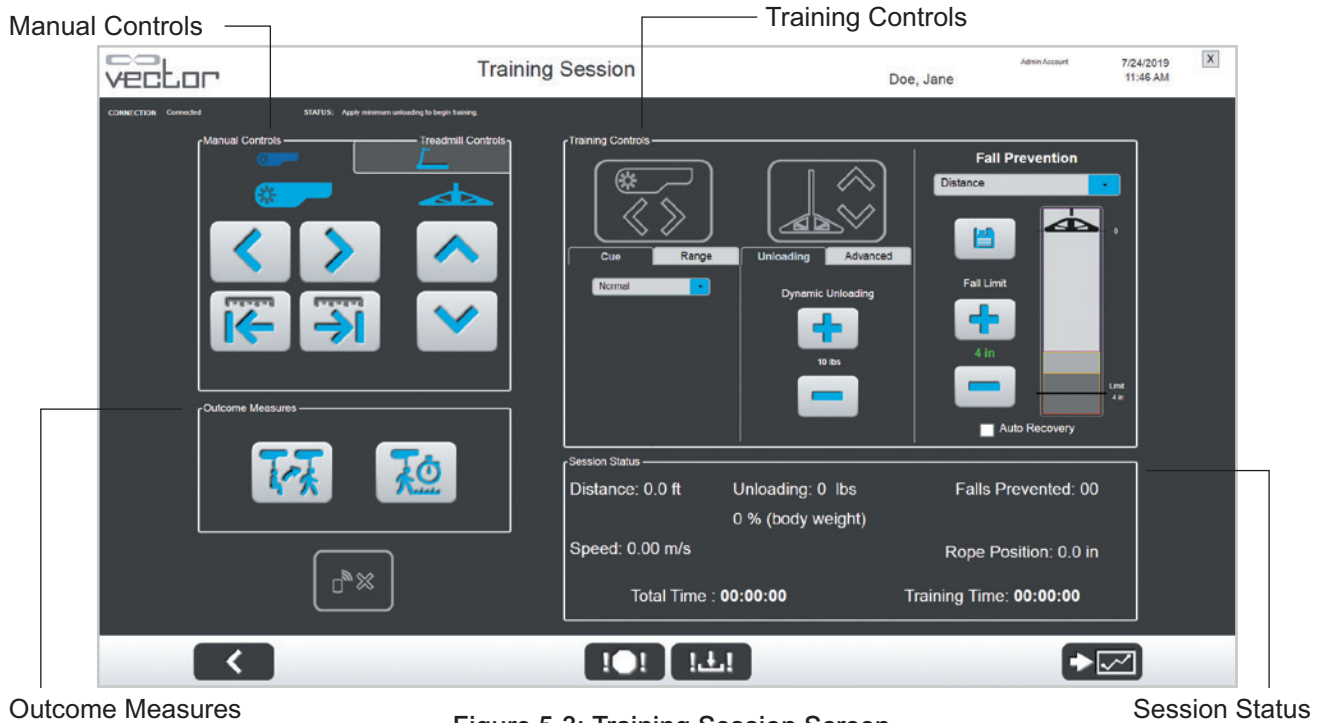

Figure 5-3: Training Session Screen

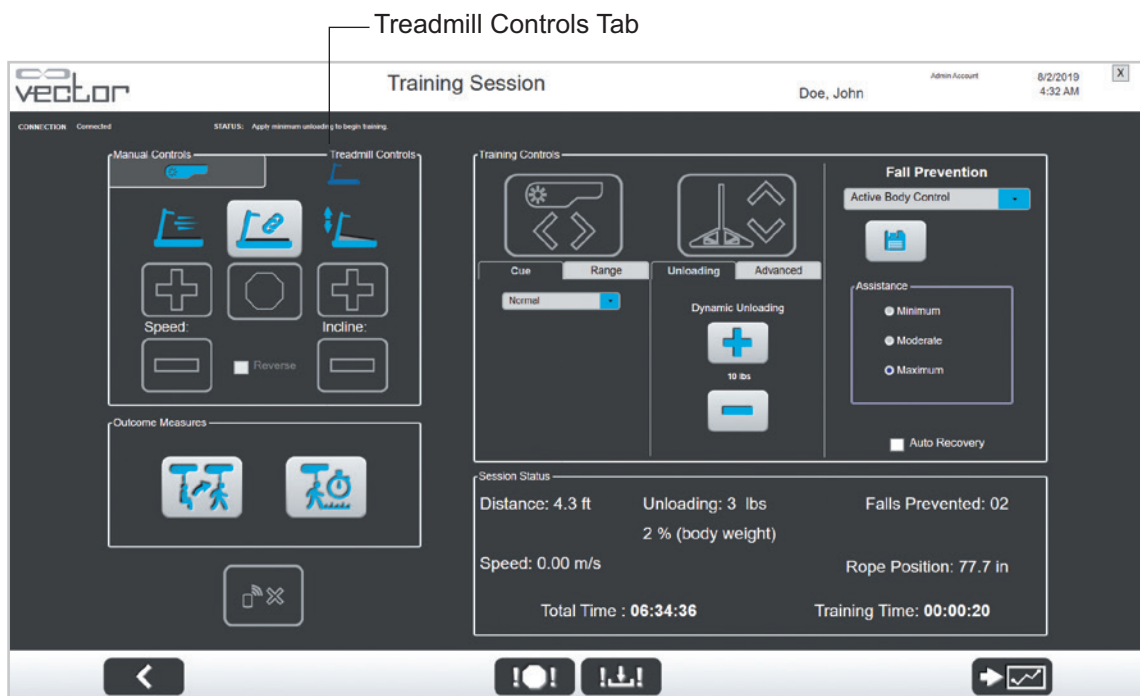

Figure 5-4: Training Session Screen for Systems with Treadmill Controls

Manual Controls

Warning: The Vector Elite system is not intended for patient transport. Using the system as a transport could cause serious patient injury.

When the Training Session Screen opens, only the Manual Controls are enabled. See Figure 5-3. The Manual Controls allow the user to winch the rope up and down, and move the trolley along the track. See Table 5-1.

The Manual Control buttons are used to position the trolley on the track, lower the Support Rope to connect the patient harness to the spreader bar, and winch up the Support Rope to the desired tension.



Manual Control Button	Definition
	Winches the Support Rope and Spreader Bar up and down until the button is released.
	Moves the trolley along the track in the direction indicated until the button is released. Reference the trolley icon to determine the direction of the movement.
	Moves the trolley 18 inches (45.7 cm) along the track in the direction indicated and stops. Reference the trolley icon to determine the direction of the movement.

Table 5-1: Manual Control Button Definitions

To manually winch down, there must be a minimum tension of 0.5 lbs. (0.23 kgs.) applied to the rope. This is achieved by allowing the spreader bar to hang freely. This minimum tension prevents damage to trolley hardware pieces including the winch drum, finger guard, and rope. If at any time a manual winch-down is initiated or in process, and the minimum tension cannot be detected by the system, a warning message window will be displayed. See Figure 5-5.

Once the minimum tension has been applied the amount of unloading will be displayed in green. Press the X button to close out of the warning message window and continue to winch down.

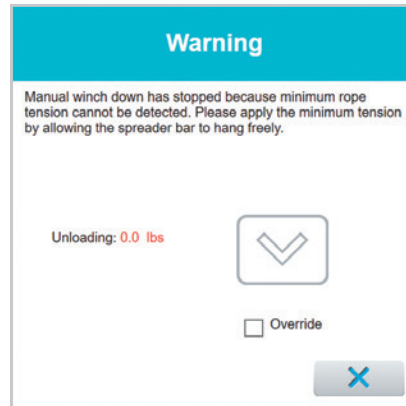

Figure 5-5: Warning Message Window - Minimum Rope Tension

If you must continue winching down without the necessary minimum tension, check the “Override” box. This enables the winch down button on the popup screen. Once complete, close out by selecting the X button to continue using the system normally.

Note: Manual positioning of the trolley posterior or anterior to the patient may be desired for exercises such as sit-to-stand. In these cases, first reduce unloading to 10 lbs, position trolley, and then increase unloading to desired value. (See pages 18-19 for more information on Dynamic Body Weight Support and Dynamic Unloading)

Training Controls

In order to enable the Training Controls, the Vector Elite system must detect a load of at least 10 lbs. (4.5 kgs.). See Figure 5-6.

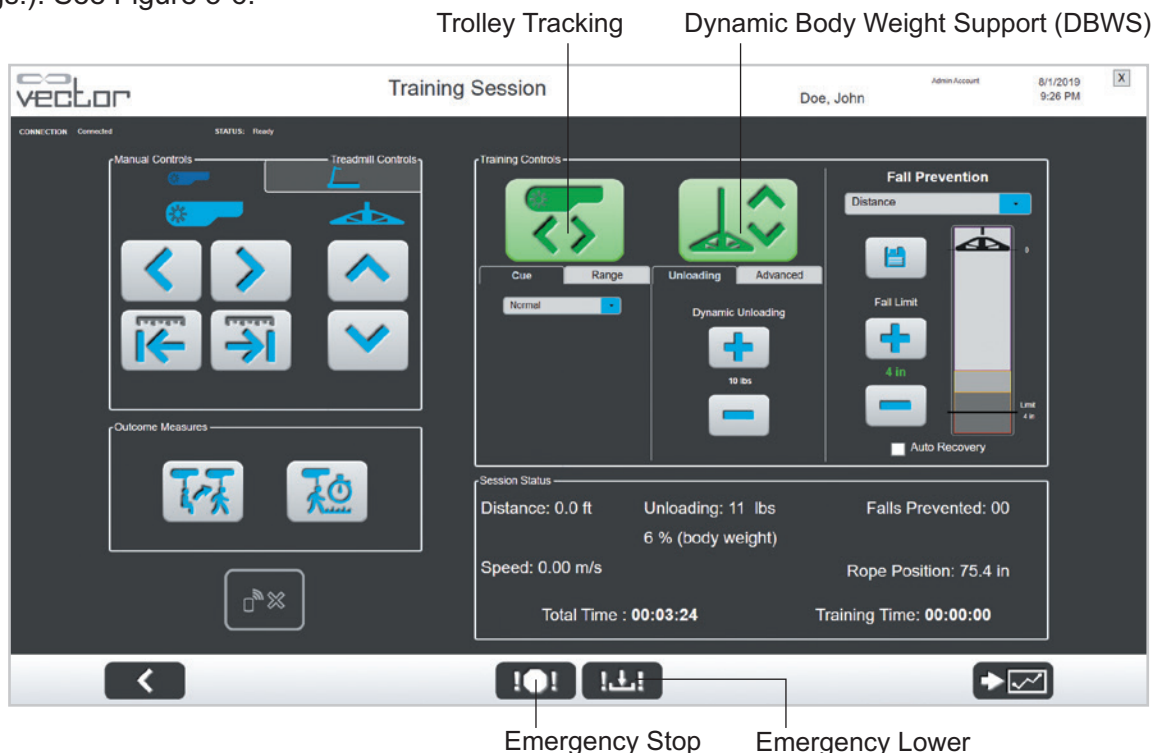

Figure 5-6: Training Session Screen with Training Controls Section Enabled

Trolley Tracking



The Trolley Tracking feature keeps the trolley at a desired location relative to the patient. In the normal default setting, the trolley remains directly above the patient during a training session.

To change the settings, press the More Training Options button. See Figure 5-6. Then the More Training Options window will appear. See Figure 5-7.

Dynamic Body Weight Support (DBWS)



The Dynamic Body Weight Support (DBWS) feature keeps the rope tension at a desired value. As the patient moves, the trolley will make adjustments to keep the dynamic unloading at the specified value. The amount of dynamic unloading is controlled by the plus (+) and minus (-) buttons and is shown in pounds (or kilograms) and body weight percent.

A minimum unloading of 10 lbs. (4.5 kgs.) must be detected in order to initiate DBWS. If the static unloading value and the Dynamic Unloading differs by more than 75 lbs. (34 kgs.), the system will not allow DBWS to be activated. Manually adjust the static unloading value as close as possible to the intended Dynamic Unloading setting.

Once activated, the DBWS feature will remain on until the button has been turned off, a fall is detected, or until the dynamic unloading force falls below 3 lbs. (1.36 kgs.).

Dynamic Unloading



The default Dynamic Unloading setting is 10 lbs. (4.5 kgs.). Dynamic unloading can be adjusted between 10 lbs. (4.5 kgs.) to 200 lbs. (91 kgs.). Use the plus (+) and minus (-) buttons to change the settings. The Dynamic Unloading setting value will be displayed between the buttons. Each tap of the + and - button equals a one-unit (lb. or kg.) change. Press and hold the up or down button to quickly adjust in five-unit increments.

Fall Prevention Drop-Down Menu



Figure 5-7: Training Session Screen - Training Controls Enabled

Fall Prevention

The Fall Prevention setting has three modes. Use the Fall Prevention drop-down menu to select between Distance, Active Body Control, or Disabled. See Figure 5-7. When a fall is detected, the Vector Elite system locks the rope winch, stops the trolley and engages the breaks, and deactivates DBWS and Trolley Tracking (if active).

Distance

The Fall Prevention default mode is Distance. Distance mode will detect a fall when a patient's downward vertical movement has exceeded the distance defined by the Fall Limit setting. The default Fall Limit setting is 4 inches (10 cm). The Fall Limit setting can be set from 1 inches (1 cm) to 36 inches (91 cm), at the user's discretion depending on the training activity.

Distance Fall Limit can be adjusted in increments of 1 inch (or 1 cm) by pressing the plus (+) and minus (-) buttons.

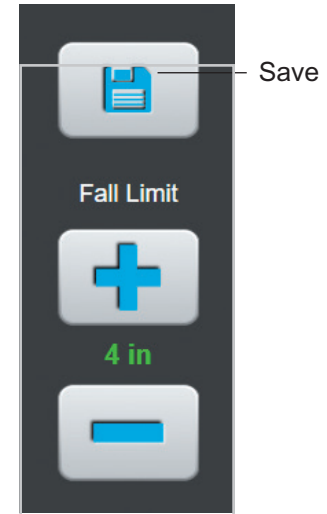

Figure 5-8: Fall Limit



When the Fall Limit setting has been changed, the value will appear in red text. The Save button changes to red. Press the Save button to save the Fall Limit setting value and zero point. Make sure the Fall Limit setting value appears in green text. If not, press the Save button to ensure that the Fall Limit setting has been saved properly.

The animated graphic bar next to the Fall Limit visually shows how close to the Fall Limit value the patient is at any given time. See Figure 5-8.

Active Body Control

Active Body Control, or ABC, is a Fall Prevention mode that detects falls based on force measurements. The clinician can choose one of three levels, based on the level of system-provided assistance desired:

- Minimum (least sensitive fall detection)
- Moderate
- Maximum (most sensitive fall detection)

Select Active Body Control from the drop-down menu and then use the radio button to select the level of assistance. Press the Save button to save the selection. See Figure 5-9.

Note: The Save button changes to red when the level of assistance is changed.



Figure 5-9 Fall Prevention Active Body Control

Disabled

Fall Prevention can also be disabled. To disable Fall Prevention, select Disabled from the drop-down menu and press the Save button.

⚠ Caution: Extra precautions should be taken with the patient when the Fall Limit is disabled, due to the possibility of patient injury.

Auto Recovery

If a fall is detected while Auto Recovery is enabled, the system will maintain rope tension allowing the patient to self-correct and stand up without assistance while preventing the patient from descending farther. When the patient reaches the original standing position, Trolley Tracking and DBWS will resume their normal operation. Auto Recovery is enabled when the check box is selected. See Figure 5-10. The clinician can cancel the Auto Recovery feature at any time by pressing the manual winch up or down button on the Auto Recovery pop-up window. See Figure 5-10.

Note: The Auto Recovery setting (i.e. selected or not selected) will persist between training sessions for a given patient.

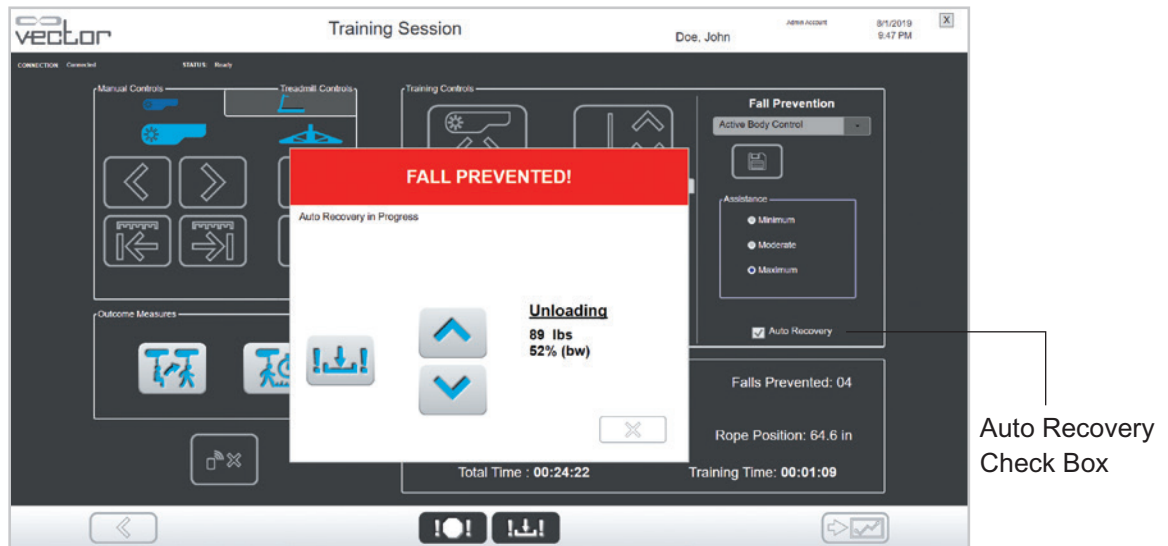

Figure 5-10: PC Auto Recovery Dialog Box

Treadmill Controls

The Vector software can be used to control a compatible treadmill from the Treadmill Controls Tab. After connecting the treadmill to the Vector software, controls for start, stop, speed, incline, and belt direction will be available. See Figure 5-16.

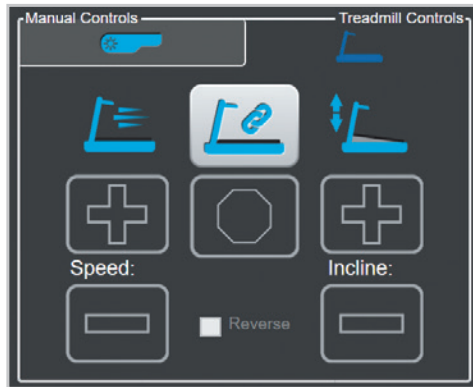

Figure 5-11: Treadmill Controls Tab without Treadmill Connected

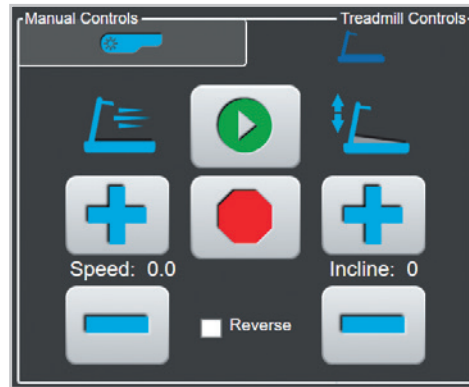

Figure 5-12: Treadmill Controls Tab with Treadmill Controls Enabled

Outcome Measures

The Outcome Measures section is displayed on the Training Session screen. Outcome Measures features two tests that may be launched during an ongoing training session. See Figure 5-4. The two Outcome Measures tests are:

- Timed Up and Go (TUG) Test
- Walking Test

TUG Test Button



The TUG Test button is used to navigate to the Timed Up and Go (TUG) Test screen. From this screen a TUG test may be initiated and recorded with the patient secured in the Vector Elite system.

Walking Test Button



The Walking Test button is used to navigate to the Walking Test screen. From this screen a 10 meter walk test, 5 meter walk test, 6 minute walk test, or 2 minute walk test may be initiated and recorded with the patient secured in the Vector Elite system.

Session Status Section

The Session Status section displays real-time information during a training session, including: the amount of weight unloaded, total session time, training time, walking speed, rope position, number of falls prevented, and total distance walked during the training session.

Emergency Stop and Emergency Lower Buttons

In emergency situations, the clinician may use the Emergency Lower or Emergency Stop buttons, found at the bottom of the Training Session screen. See Figure 5-3.

Emergency Stop Button



The Emergency Stop button stops the trolley and locks it into one position. When the system is in Static Unload Mode, the position of the rope will be maintained regardless of patient movement.

Emergency Lower Button



If a patient becomes medically unstable, press the Emergency Lower button, and the system will continue to winch down the rope, with controlled velocity, until the patient has reached the ground or until the dynamic unload force goes below the default value.

Preparing for a Training Session

If the clinician is using an open track, place markings on the floor to designate the end of the track, if the track does not terminate at a wall or other obstruction. Instruct the patient to stop prior to the marking, or else the trolley will hit the end of track Bumpers. If the patient hits a bumper, they should turn around and continue their training in the reverse direction on the track.

For multi-trolley configured systems make sure the correct Computer and Remote Control are being used before starting a training session. Determine which trolley the patient will use and find the trolley serial number printed on the trolley label. The corresponding computer will have the trolley serial number printed on a label located in the upper right corner of the screen. The corresponding remote control will have the trolley serial number printed on a label located on the back of the remote control. See Figure 5-13.

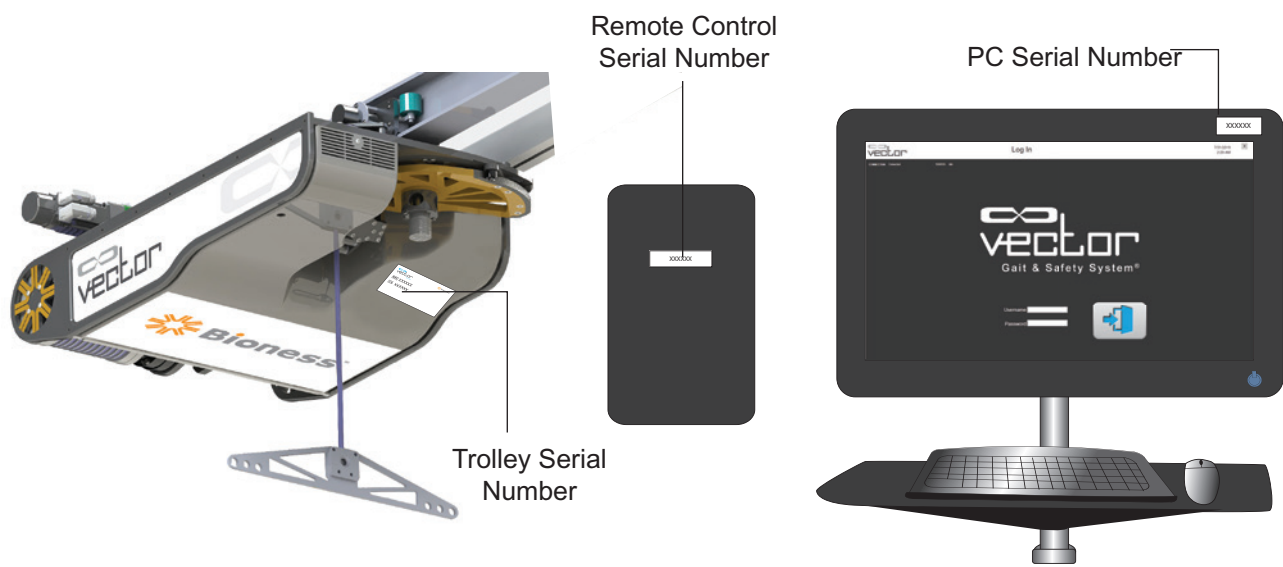

Figure 5-13: Serial Number Locations

Attaching a Patient Harness to the Spreader Bar

After the patient has been securely fitted in the harness, attach the harness to the spreader bar. Refer to Chapter 3 for patient harness fitting instructions.

1. Secure the patient.
2. Use the manual control winch down button to lower the rope with spreader bar attached.
3. The spreader bar provides three attachment points to attach a patient harness. The selection of the attachment point depends on the size of the patient. Connect the patient harness to the outermost attachment points for broader patients, and to the innermost points for thinner patients. See Figure 5-14.
4. Connect the spreader bar carabiners to the D-rings on the patient harness shoulder straps. Check to make sure the connection is secure.
5. Use the manual control winch up button to slowly raise the Support Rope until there is tension in the rope and patient harness shoulder straps.

Note: When using the manual control buttons with a patient attached to the spreader bar, let the patient know that the trolley is about to be moved.

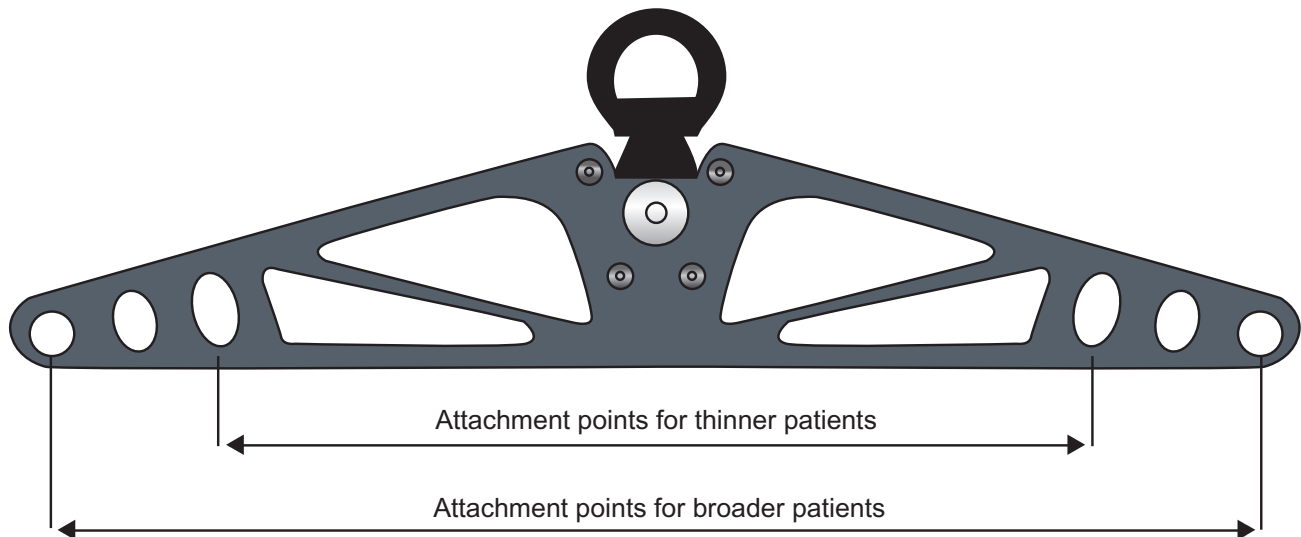

Figure 5-14: Spreader Bar Attachment Points

Starting a Training Session

A clinician or assistant must stay by the PC Computer or Remote Control to operate the Vector Elite system software controls during training sessions. A training session must be launched from the PC Computer and not from the Remote Control.

1. From the Main Menu screen, press Patient Training.
2. Select desired patient's name.
3. Press the Start Training button to open the Training Session screen.
4. To enable the Training Controls section, use manual control winch up button to create tension in the Support Rope and patient harness shoulder straps. Once the Vector Elite system has detected a load of at least 10 lbs. (4.5 kgs.), the Training Controls section will be enabled for use.
5. The default setting for dynamic unloading is 10 lbs (4.5 kgs). To adjust the setting use the plus (+) or minus (-) buttons. The revised value will display in the text between the buttons. This value must be within 75 lbs. (34 kgs.) of the current unloading value in order to activate DBWS.
6. The default mode for Fall Prevention is Distance with a Fall Limit of 4 inches (10 cm). Use the drop-down menu to change the Fall Prevention mode, or use the plus (+) or minus (-) buttons to adjust the Fall Limit setting. Press the Save button to save the revised Fall Prevention mode.
7. To activate Trolley Tracking, apply at least 10 lbs. (4.5 kgs.) of load by using the manual Manual Controls to winch the Support Rope and Spreader Bar, and press the Trolley Tracking button. The button will change from green to red. See Figure 5-19.
8. To activate Dynamic Body Weight Support, press the DBWS button. The button will change green to red indicating that the feature is turned on. See Figure 5-19.



Figure 5-15: Training Session Screen (Trolley Tracking and DBWS Active)

Note: If DBWS feature is not activated (the button is green), and the system is in Static Unload mode. The position of the rope will be maintained regardless of patient movement.

Note: The Trolley Tracking feature and DBWS feature can be activated one at a time or together

Changing Fall Prevention Mode During a Training Session

The Fall Prevention mode can be changed during a training session.

1. Use the Fall Prevention drop-down menu to select: Distance, Active Body Control or Disabled.
2. Press the Save button to save the revised Fall Prevention mode.

Adjusting the Dynamic Unloading Value During a Training Session

The dynamic unloading value can be adjusted while the DBWS feature is active.

1. To adjust the Dynamic Unloading value, use the plus (+) or minus (-) buttons. The adjustment is instantaneous and will be applied while the patient is actively training.

Adjusting the Fall Limit Value During a Training Session

The Fall Limit can be adjusted while DBWS and/or Trolley Tracking feature are active.

1. To adjust the Fall Limit setting, use the plus (+) or minus (-) buttons and the revised value will appear in red text. The Save button will also appear red.
2. Press the Save button to save the revised value. The text between the buttons will turn green.

Note: The Save button must be pressed in order for the revised Fall Limit setting to be enabled.

Once the Save button has been pressed, the Zero Point of the Fall Limit will readjust. The Zero Point represents the height of the spreader bar from which the Fall Limit is measured. If the text between the plus (+) and minus (-) buttons are red, the revised value has not been saved and the Zero Point is still reading from the last saved Fall Limit. See Figure 5-16.

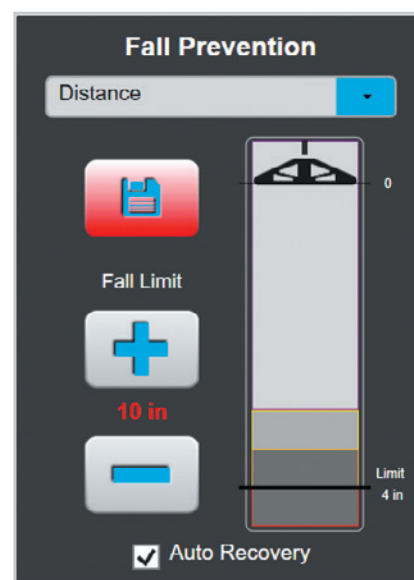

Figure 5-16: Fall Prevention Distance

Changing the Assistance Level During an Active Body Control Session

During a training session, change the level of assistance with Active Body Control Fall Prevention.

1. Select the desired assistance level in the Assistance radio button's selection: minimum, moderate, maximum. The Save button will turn red.
2. Press the Save button to save the revised assistance level. See Figure 5-17.

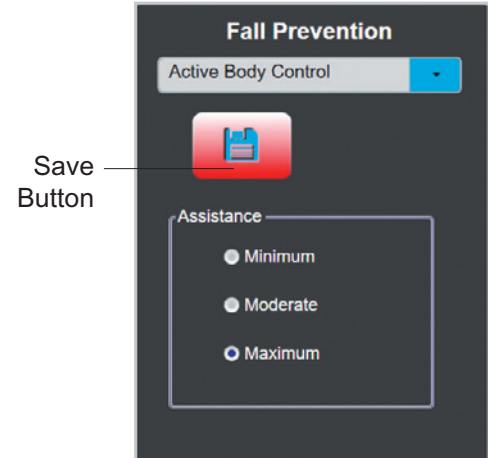

Figure 5-17: Fall Prevention Active Body Control

Fall Limit Detection

The Vector Elite system can detect and prevent a fall when the fall distance from the Zero Point is equal to or greater than the set Fall Limit setting or when the saved Active Body Control assistance level is exceeded. When the system detects and prevents a fall, the trolley locks and goes into Static Unload mode.

1. When the Vector Elite system software detects a fall, the Fall Prevented window will appear. See Figure 5-18.
2. When Auto Recovery mode is not active, press the winch up button, to bring the patient to the desired position. If necessary, use the Emergency Lower button to lower the patient to the ground.
3. Press the X button to close the Fall Prevented window. If the patient is in a standing position, press the DBWS button and (if applicable) the Trolley Tracking button to resume the training session. There must be at least 10 lbs. (4.5 kgs.) of unloading in order to activate DBWS or Trolley Tracking.

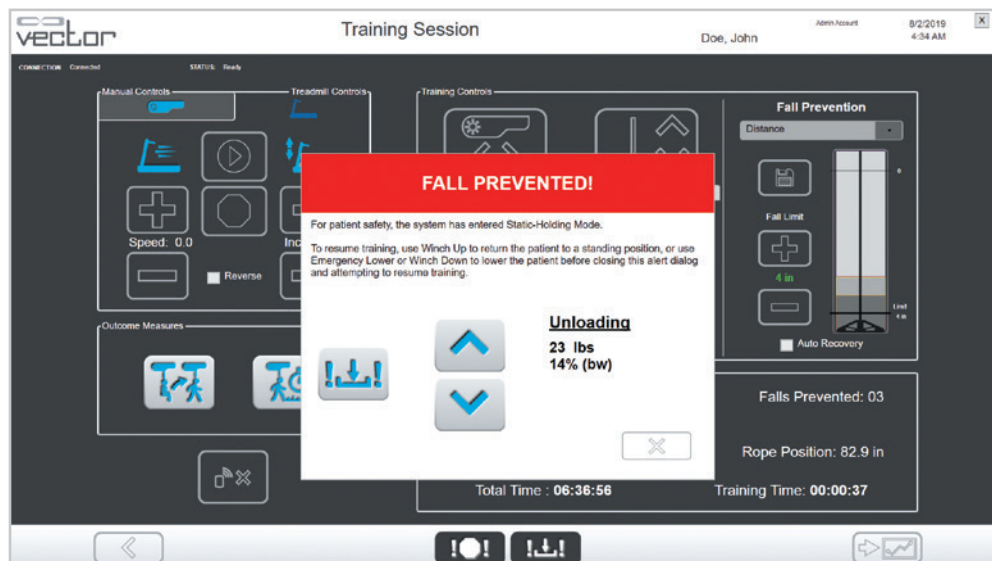

Figure 5-18: Fall Prevented Window

Auto Recovery

If a fall is detected while Auto Recovery is enabled, a Fall Prevention window will be displayed indicating that Auto Recovery is in progress. See Figure 5-19.

1. Allow the patient to self-correct and stand up without assistance.
2. When the patient reaches the original standing position, Trolley Tracking and DBWS will resume their normal operation automatically.
3. The clinician can cancel the Auto Recovery feature at any time by pressing the manual winch up or down button on the Fall Prevented window.

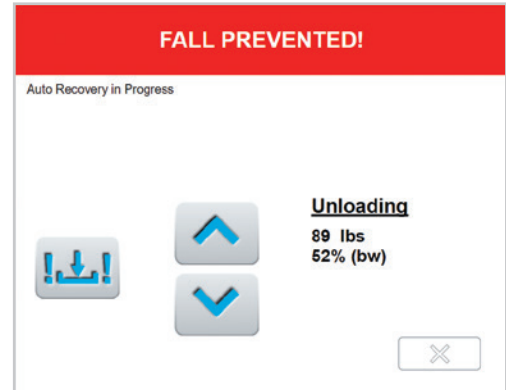

Figure 5-19: Fall Prevented Window

Stopping a Training Session

Both DBWS and Trolley Tracking should be turned off (inactive) before stopping a training session. Depending on the unloading value, the Trolley Tracking and DBWS buttons will be green (>10 lbs.) or grayed out. To end a training session, press the Previous Screen button. See Figure 5-20. Once a training session ends the Fall Limit setting will return to the default value. The Dynamic Unloading and Auto Recovery settings used with each patient will carry over between training sessions.



Figure 5-20: Training Session Screen (Trolley Tracking and DBWS Inactive)

Session Summary Screen

The clinician can record notes for each training session, including the activities performed, level of exertions, and the assistive device used. Since the training is still in progress, the contents of the Session Summary section that includes the average speed and total time is empty. The contents of the Session Summary section will be completed after the training session.

1. From the Training Session screen press the Session Summary button. See Figure 5-20.
2. The Session Summary screen will open. See Figure 5-21.
3. Record the session notes and press the Save button.
4. After session notes have been recorded, press the Back button to go back to the Training screen.

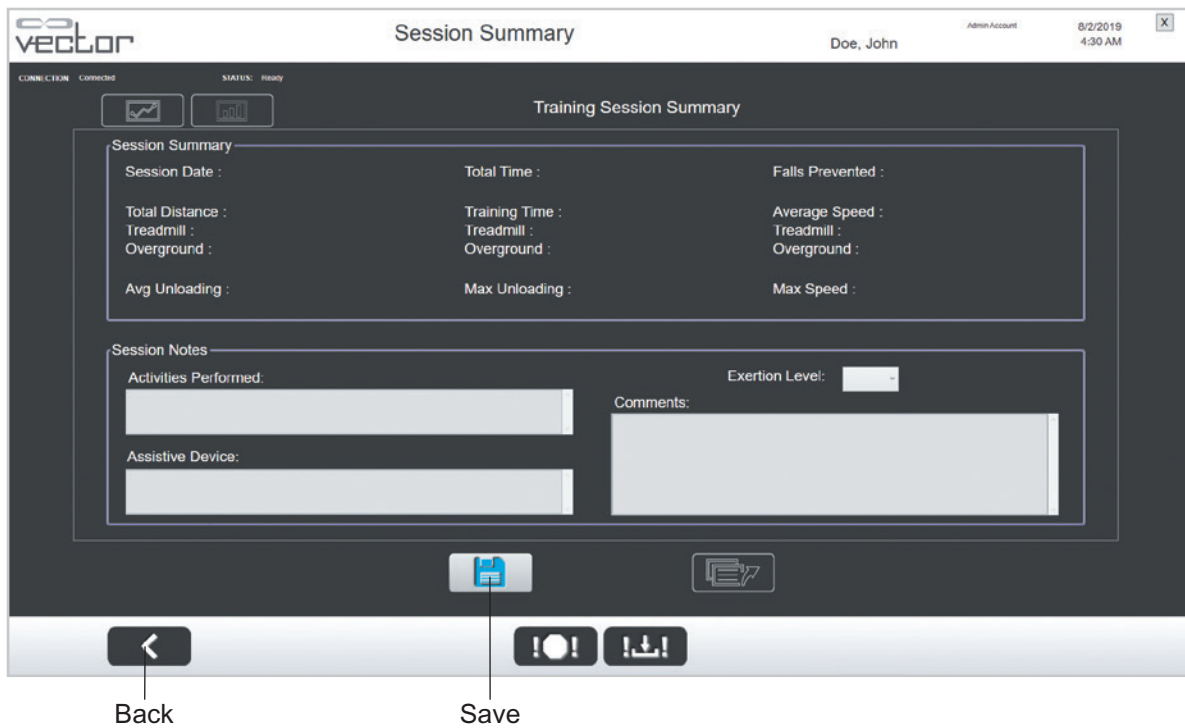

Figure 5-21: Session Summary Screen During Active Training Session

Vector Elite Time-Out Feature

If Vector Elite software detects no activity for 15 minutes, the system logs out automatically. See Figure 5-22. The Time-Out feature will not activate during a training session.

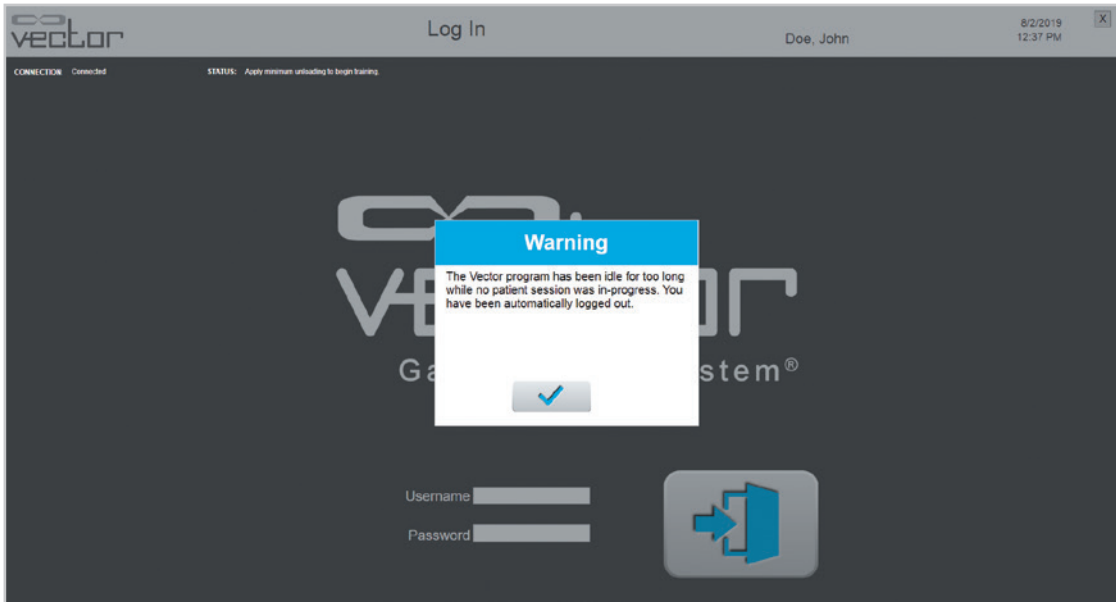

Figure 5-22: Vector Time-Out Window

Advanced Training Features

Advanced Trolley Tracking

In addition to the basic Trolley Tracking functionality, two aspects of Trolley Tracking behavior can be customized from the Training Session screen. See Figure 6-1.

Trolley Cue: Adjustment of trolley position relative to the patient.

Trolley Range: Restriction of trolley movement within a specified distance from a specified point.

Trolley Cue

Posterior Cue & Anterior Cue: This feature maintains Trolley Tracking at a fixed Cue Angle posterior or anterior of the patient and includes an option for Homing. With Homing enabled, the system monitors trolley movement and disables cueing to keep the trolley directly overhead when the patient is stationary.

Note: The option to disable Homing is only available from the Training Screen on the Vector PC. Homing cannot be disabled from the Vector Remote software.

Anterior Chase: This feature encourages the patient to increase walking speed up to a target walking speed which is adjusted by the clinician. When the patient begins walking, the system will monitor the patient's speed for a period of 5 seconds. Once the patient's speed is determined, the trolley will position itself anterior to the patient applying a horizontal force equal to 4% of the patient's body weight, but the horizontal force will not exceed 10 lbs. The anterior position of the trolley will vary depending on the set unloading, but the rope angle will not exceed 15°.

The trolley will continue to follow the patient from its anterior position and match the patient's velocity. When walking speed falls below 0.1 m/s Anterior Chase mode will stop automatically, and the trolley will home overhead.

Enabling Posterior Cue & Anterior Cue

1. Select the Cue Tab. A drop-down menu will be displayed. See Figure 6-1.



Figure 6-1: Advanced Trolley Tracking Cue Tab

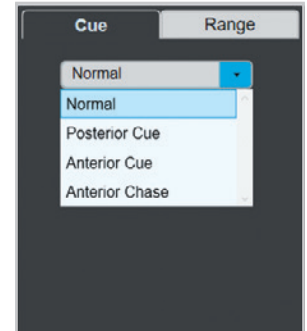

Figure 6-2: Trolley Cue Mode Drop-Down Menu

2. Open the drop-down menu and select the Posterior Cue or Anterior Cue mode. See Figure 6-2.
3. If desired, select the Homing option to require the trolley to return to an overhead position when the patient is stationary. See Figure 6-3. Deselecting the Homing option will maintain an angled position when the patient is stationary.

Note: The Homing option is enabled by default.

4. Cue Angle may be adjusted to increase or decrease the rope angle from the vertical orientation by selecting the Minimum, Moderate, or Maximum radio buttons. See Figure 6-3.

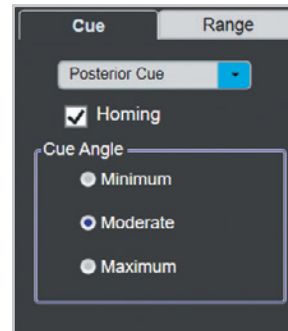

Figure 6-3: Homing & Cue Angle

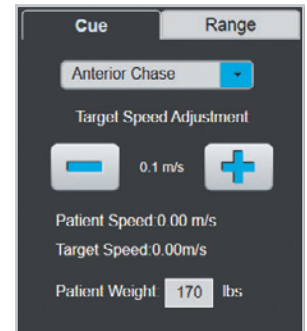

Figure 6-4: Anterior Chase Controls

Note: The trolley will remain in its overhead position before the patient begins walking.

Enabling Anterior Chase

1. Select the Cue Tab from the training screen. A drop-down menu will be displayed. See Figure 6-2.
2. From the drop-down menu, select Anterior Chase.
3. The patient body weight will be displayed in the Cue Tab, and this value may be adjusted from the Training Screen as needed to ensure accuracy.
4. Set the target speed by pressing the plus (+) and minus (-) buttons. See Figure 6-4.

Note: The target speed can be adjusted at any time, including before and after the patient begins walking.

Trolley Range

This feature allows the clinician to establish a virtual boundary for the trolley to operate within. This is accomplished by setting a limit on the distance that the trolley can travel from a specified location on the track.

1. Select the Range tab. See Figure 6-5.



Figure 6-5: Advanced Trolley Tracking Range Tab

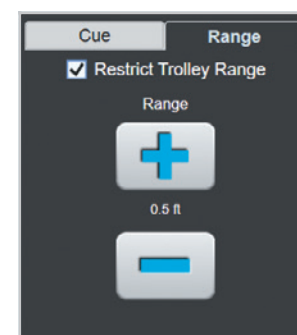

Figure 6-6: Restricted Trolley Range Active

2. Select the option to Restrict Trolley Range. See Figure 6-6.
3. Use the plus (+) and minus (-) buttons to adjust the range. See Figure 6-6.

Note: The range value applies to forward and backward motion of the trolley (e.g. setting the range to 5 ft allows the trolley to move forward 5 ft and backward 5 ft for a total of 10 ft of movement).

Advanced Body Weight Support

Advanced Body Weight Support can be used to add automation to the unloading assistance provided by the Vector Elite system during activities such as overground gait training and Sit-to-stand exercises.

Gait Smoothing

This feature automatically adjusts the set unloading based on changes in the patient's vertical displacement. If the patient's vertical displacement during gait activities exceeds a prespecified range (0.06 m/2.36 in), the Vector Elite system will automatically increase the unloading to reduce the patient's vertical displacement. If the patient's vertical displacement is less than the prespecified range, the unloading automatically decreases to provide more of a challenge for the patient. Gait

Smoothing will not decrease the active unloading below 2/3 of the original set unloading or increase it past 50% of the patient's body weight.

Ascent Assist

This feature provides the patient with vertical lift assistance for sit-to-stand activities. During the standing portion of the exercise, the system monitors the patient's standing speed. If the system determines that the patient is not standing quickly enough, the unloading will be increased to assist the patient to the standing position. Once the patient is standing, the unloading will decrease back to the original set unloading. The maximum additional unloading provided during ascent is 2/3 of the patient's bodyweight. This feature also provides decent control during the sitting portion of the exercise. The system monitors the difference between the set unloading and the actual force applied to the rope and determines if the patient is descending in a controlled manner. If the difference is sufficiently large, the system will decrease the speed at which the Winch unspools the rope. When the patient has reached their lowest point and is no longer descending, the Winch will unspool normally as needed.

Enabling Gait Smoothing

Gait Smoothing can be enabled independent of DBWS and Trolley Tracking, and it will remain enabled until it is manually disabled, even if DBWS is not enabled.

1. Select the Advanced tab. The buttons for Gait Smoothing and Ascent Assist will be displayed. See Figure 6-7.
2. Press the Gait Smoothing button to enable it. When Gait Smoothing is enabled, the button will turn red. See Figure 6-8.



Figure 6-7: Advanced Tab



Figure 6-8: Gait Smoothing Active

3. When finished with the Gait Smoothing feature, press the red Gait Smoothing button to disable it. When disabled, the button will turn green again.

Enabling Ascent Assist

1. Select the Advanced tab. The button for Ascent Assist will be displayed. See Figure 6-7.
2. Ensure DBWS is enabled and that the patient is standing, and press the Ascent Assist button. See Figure 6-7.
3. A popup message will be displayed with instructions for confirming patient weight and ensuring that the patient is standing. If the displayed weight is incorrect, it must be updated prior to using this feature. See Figure 6-8.
4. When Ascent Assist is enabled, the button will turn red. See Figure 6-9.



Figure 6-9:
Patient Weight Confirmation

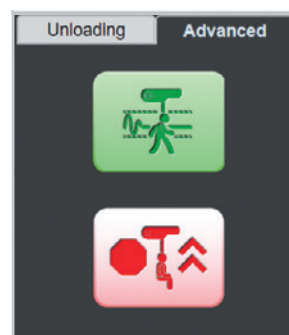

Figure 6-10:
Ascent Assist Active

5. When finished with the Ascent Assist feature, press the red Ascent Assist button to disable it. When disabled, the button will turn green again.

Treadmill Integration with the Vector Elite Software

The Vector Elite System can be used in combination with body weight supported treadmill training. Once integrated, the Vector software can be used to control the speed, incline, and belt direction of the treadmill from the PC and Remote Control devices.

Note: Treadmill integration requires a compatible treadmill. Consult your Bioness representative to determine if the Vector software is compatible with your treadmill.

Connecting the Treadmill to the Vector Elite System

1. Power on the treadmill as instructed by its associated user manual.
2. Connect the provided USB cable into the PC and treadmill. See Figure 6-11.

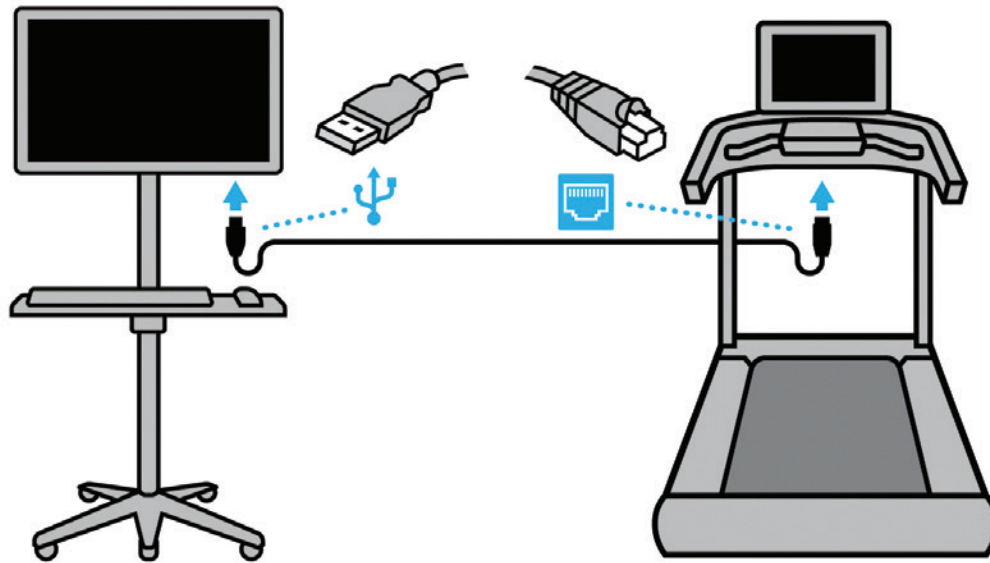

Figure 6-11: PC to Treadmill Connection

- From the Training Session screen in the Vector PC software, select the treadmill icon to open the Treadmill Controls Tab and press the Connect Treadmill button. See Figure 6-12.

Note: Manual controls are hidden when accessing the Treadmill Controls tab. To access manual controls for the trolley and spreader bar, select the Manual Controls tab.

Note: If the treadmill is not properly connected and powered on, an error will be displayed. See Figure 6-13.



Treadmill Controls Tab

Connect Treadmill

Figure 6-12: Training Session Screen with Treadmill Controls Tab Open



Figure 6-13: Treadmill Connection Error

Treadmill Controls

After establishing connection with the treadmill, the Treadmill Controls Tab on the Vector software can be used to start, stop, and modify settings on the treadmill. Speed, incline, and belt direction can be adjusted from the PC or Remote Control. See Figure 6-14.

Note: The Treadmill Control Tab will remain enabled on both the PC and Remote Control at all times, regardless of which device is being used to control the trolley.



Figure 6-14: Training Session Screen with Treadmill Controls Enabled

Note: With an established treadmill connection, the treadmill can be operated from the PC, Remote Control, or main treadmill interface. However, it is recommended to keep the treadmill on its main menu and control it primarily through the Vector software while connected.

1. To initiate a treadmill training session, press the Start button. See Figure 6-14.

Note: If the system does not detect a minimum of 10 pounds on the spreader bar, an error will be displayed and the treadmill will not start. See Figure 6-15.

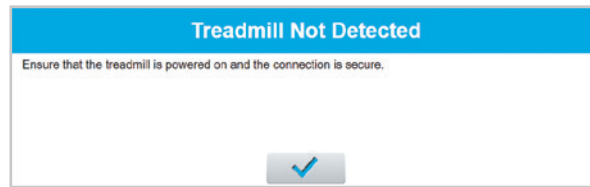

Figure 6-15: Minimum Unloading Error

2. When the treadmill is active, the Start button will be replaced by the Pause button which can be used to pause the treadmill session as needed. See Figure 6-16.
3. The (+) and (-) buttons can be used to adjust speed and incline. See Figure 6-16.
4. The treadmill belt direction can be reversed by pausing the treadmill session, then selecting the Reverse check box. See Figure 6-16.

Note: The belt direction cannot be changed while the treadmill belt is in operation, and the Reverse checkbox will not be enabled for selection until the treadmill session is paused.

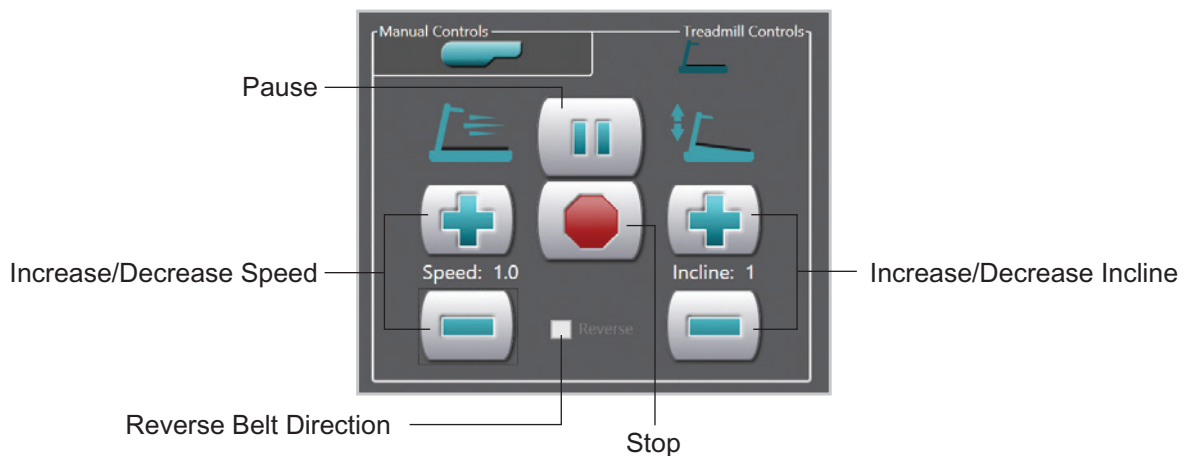

Figure 6-16: Treadmill Controls Tab with Treadmill On

5. When a fall is detected, the treadmill will stop automatically, and the treadmill controls will be disabled until the Fall Prevented dialog box is closed. See Figure 6-17.

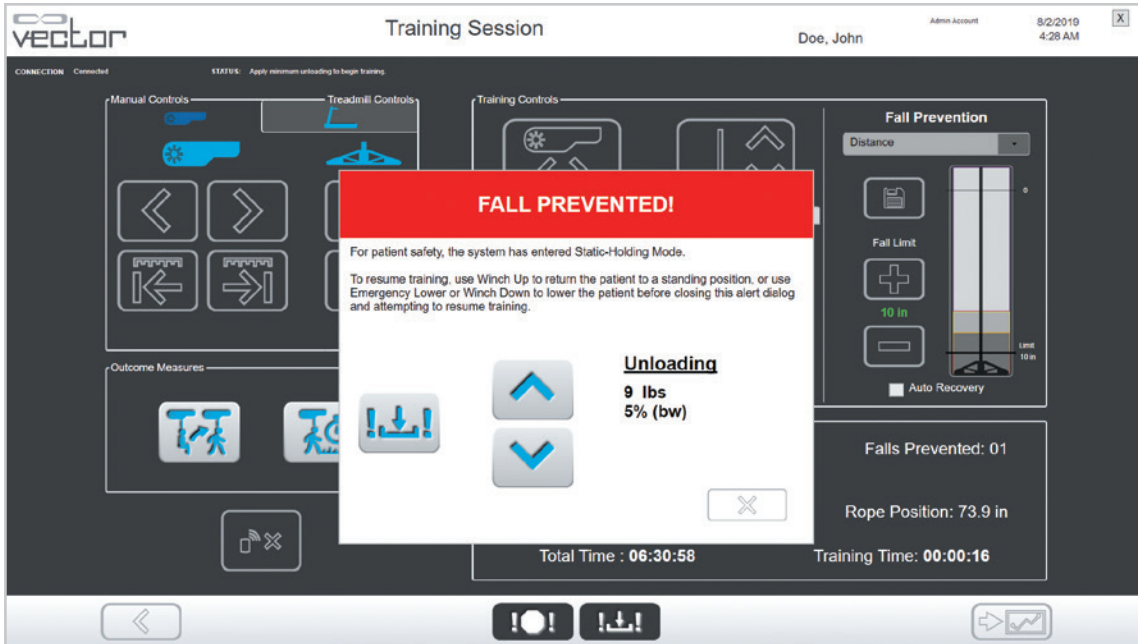

Figure 6-17: Fall Prevented Dialog Box

- To end the treadmill session, press the Stop button and confirm on the dialog box. See Figure 6-18.

Note: After the Stop button is selected, the previously used treadmill settings will be cleared, even if the Cancel button is selected on the dialog box.

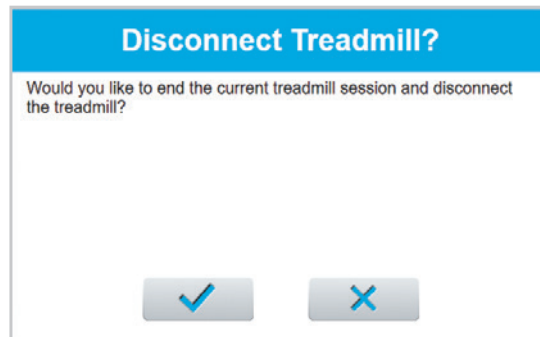

Figure 6-18: Disconnect Treadmill Confirmation Dialog Box

Vector Outcome Measures

Vector Elite systems that feature the Outcome Measures software module can run standardized tests, such as the Timed Up and Go (TUG) Test and Walking Tests. The Outcome Measures software module allows a user to start and stop a test, collect data during a test, and provide test results, graphs, and reports.

Types of Outcome Measure Tests

Timed Up and Go (TUG) Test

The TUG Test is a timed test measures balance, speed, and functional capacity for ambulation. The test begins with a patient seated in a chair. The patient is provided instructions to perform the following: stand, walk three meters, turn around, walk back, and sit back down in the chair.

Walking Tests

Walking Tests consist of a patient walking for either a specified distance or a specified length of time. Tests are timed and speed and distance are recorded. The Outcome Measures software module has four different Walking Tests.

- 5 / 10 meter Walk Test: measures walking speed at either a comfortable or fast pace.
- 2 / 6 minute Walk Test: assesses walking endurance by measuring the distance walked during a continuous period.

Preparing for an Outcome Measures Test Run

Equipment and a course will need to be set up for each Outcome Measures test. See Tables 7-1 and 7-2. Assistive devices may be used, but should be documented and kept consistent from test to test.

Equipment List

Type of Outcome Measure Test	Equipment List
TUG test	<ul style="list-style-type: none"> • Vector System (with appropriate harness size) • Tape measure • Cone • Chair
5 / 10 meter walk	<ul style="list-style-type: none"> • Vector System (with appropriate harness size) • Tape measure and tape (optional)
2 / 6 minute walk	<ul style="list-style-type: none"> • Vector System (with appropriate harness size) • Cones or appropriate floor markings

Table 7-1: Equipment List

Course Setup

Follow the course setup instructions in the table below for each Outcome Measures test type. Make sure the entire course is within a usable track space that avoids any obstacles and track end stops.

Note: Using the same section of track for all test runs (of each test type) will help provide more consistent results.



Type of Outcome Measure Test	Course Setup
TUG Test	<p>Set up a course, 3 meters in length, with the chair on one end and the cone on the opposite end.</p> 
5 Meter Walk	<p>Set up a course, 5 meters in length, with a minimum of 2 meters of space on either end to allow for acceleration and deceleration. If possible, use a straight section of track. Place markers (optional) at 0, 2, 7, and 9 meters.</p> 
10 Meter Walk	<p>Set up a course, 10 meters in length, with a minimum of 2 meters of space on either end to allow for acceleration and deceleration. If possible, use a straight section of track. Place markers (optional) at 0, 2, 12, and 14 meters.</p> 
2 / 6 Minute Walk	<p>Set up a course of the longest length possible marked on either end (for a straight track). If possible, use a closed loop track to avoid turn around points.</p>

Table 7-2: Course Setup

Starting an Outcome Measures Test Run

1. Make sure the patient is properly fitted in a harness and the harness is securely attached to the Spreader Bar.
2. From the Patient Menu screen, select a Patient Record.
3. Press the Start Training button to open the Training Session screen.
4. Activate training to launch a training session. Refer to the "Starting a Training Session" section of this guide for more information.
5. Adjust Dynamic Unloading and Fall Prevention, if needed.

Note: All Training Controls (Trolley Tracking, Dynamic Body Weight Support, and Fall Limit) will remain active and at the selected settings before, during, and after an Outcome Measures test. These settings can be adjusted during an Outcome Measures test.

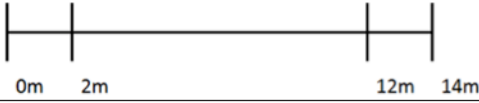
Timed Up and Go (TUG) Test

1. From the Training Session screen on the PC use the Vector manual controls to position the patient at the start of the course, seated in the chair. Activate Trolley Tracking and Dynamic Body Weight Support by pressing the Trolley Tracking and DBWS buttons.
2. Press the Timed Up and Go (TUG) Test button. See Figure 7-1.



Figure 7-1: Training Session Screen

3. The Outcome Measures TUG Test screen will open.
4. When you and the patient are ready, press the Start button. See Figure 7-2.

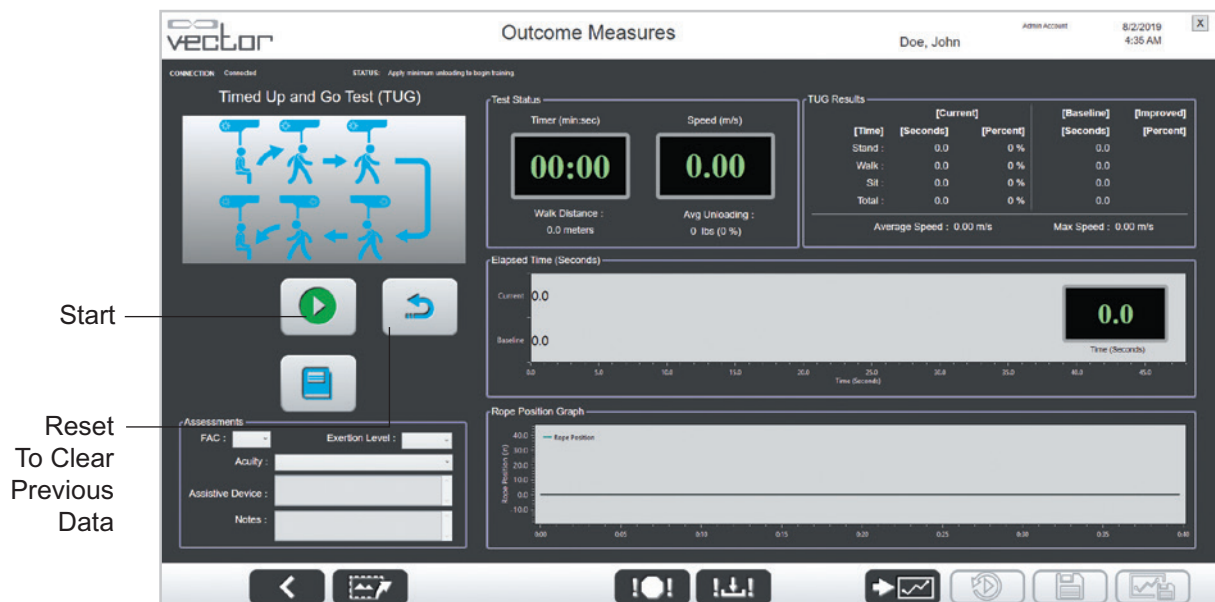

Figure 7-2: Outcome Measures TUG Test Screen

5. A Get Ready to Start window will appear and the countdown will begin. See Figure 7-3.



Figure 7-3: Get Ready to Start Window

6. The patient will then stand, walk out 3 meters to the cone, turn around by walking around the cone, walk back, and return to a seated position in the chair. Once the patient sits back in the chair, press the Stop button to end the TUG test. See Figure 7-4.

Note: The Stop button can be pressed at any time to cancel the test.

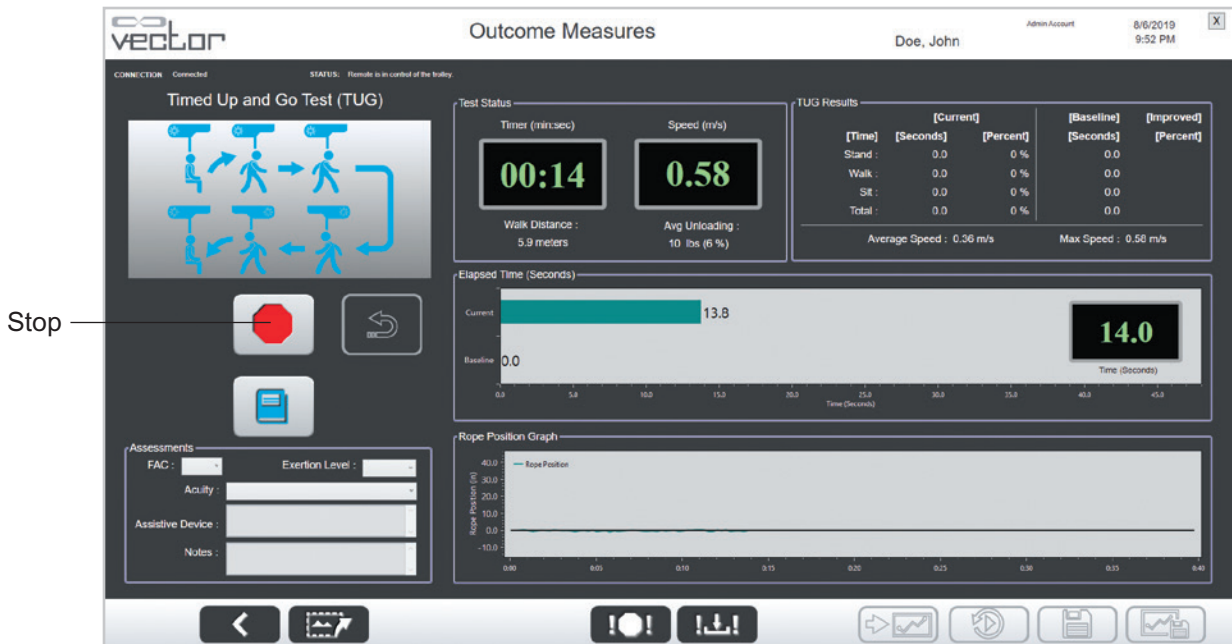

Figure 7-4: Outcome Measures TUG Test Screen (Active Test)

7. The test results and graphs are displayed on the screen. The TUG test time is displayed in the Test Score Box. To review the test, press the Playback button. See Figure 7-5.
8. Complete the Assessments section. See Figure 7-5.
9. **You must press the Save Button to save test results.** See Figure 7-5. If the button is not pressed before starting another test run or before leaving the screen, the current test run results will not be saved to the patient summaries.

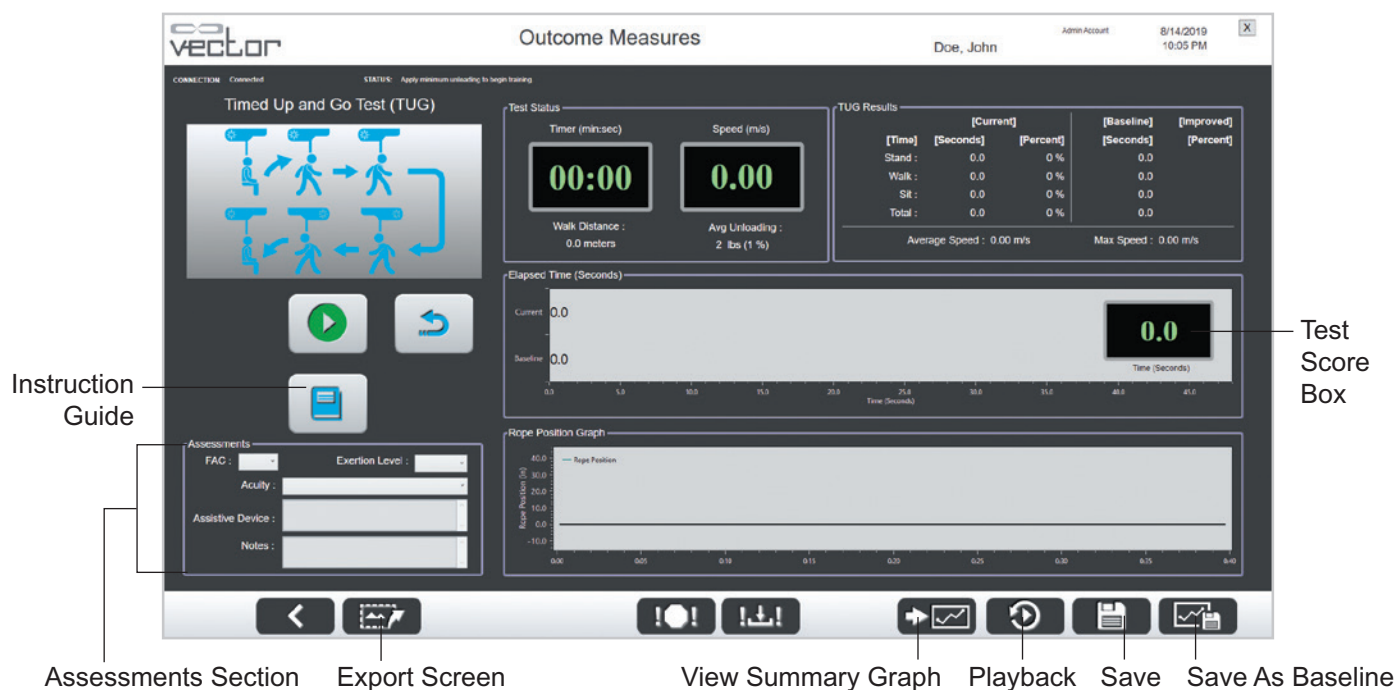

Figure 7-5: Outcome Measures TUG Test Screen (Test Results, Graphs, and Buttons)

10. To save the current test as a baseline for the Outcome Measures TUG Test press the Save As Baseline button. See Figure 7-5.
11. To export the current test screen as a screen capture image, press the Export Screen button. See Figure 7-5. When the Export Screen button is pressed, the software saves the test screen as a PNG file and a Save As window will appear. Select the location to save the file and press the Save button.
12. Before starting another test, press the Reset button to clear the previous test results.
13. To view all the of TUG results for a given patient, press the View Summary Graph button. Outcome Measures Summary Graph window will appear.

Note: When pressed, the Instruction Guide button found on the Outcome Measures TUG Test screen, opens a window that displays the TUG Test Instructions from this guide. See Figure 7-5.

Walking Tests

1. Position the patient at the start of the course.
2. From the Training Session screen, activate Trolley Tracking and Dynamic Body Weight Support by pressing the Trolley Tracking and DBWS buttons.
3. From the Training Session screen, press the Walking Test button.
4. The Outcome Measures Walking Tests (timed & distance) screen will open.
5. From the Walk Test section select the type of walk test, a 5/10 meter test or a 2/6 minute test. See Figure 7-6.
6. For the 5/10 meter test type, make a secondary selection of 5 meters or 10 meters and select a walking speed of comfortable or fast.
7. For the 2/6 minute test type, make a secondary selection of 2 minutes or 6 minutes.



Figure 7-6: Outcome Measures Walking Tests (Timed & Distance) Screen

8. When you and the patient are ready, say “Ready and Go.”
9. **For the 5 or 10 meter walk test:** Press the Start button, see Figure 7-6, when the patient has accelerated to their comfortable/fast walking pace. If you have placed markers, press the Start button when the patient's front foot crosses the 2 meter mark.
 - The test collection will continue and automatically stop when a distance of 5 or 10 meters has been walked.
10. **For the 2 or 6 minute walk test:** Press the Start button, see Figure 7-6, when the patient begins to walk. The patient will need to continuously walk as far as possible during a 2 or 6 minute period.
 - The test collection will continue and automatically stop when a time of 2 or 6 minutes has been reached.

Note: Press the Stop button to cancel the test. See Figure 7-7. The test will automatically stop at the selected distance or time.

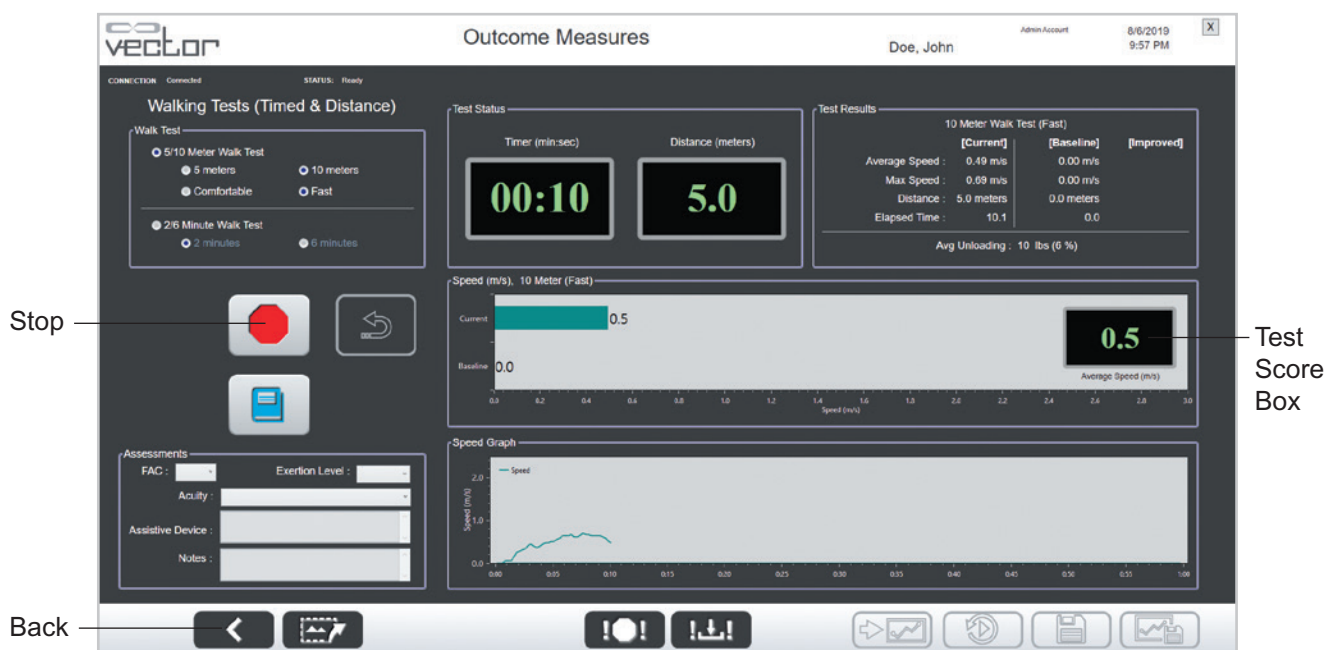

Figure 7-7: Outcome Measures Walking Test Screen (Active Test)

11. The test results and graphs will be displayed on the screen. The Walk Test Score will be displayed in the test score box. See Figure 7-8. For a 5/10 meter Walk Test the Test Score is gait speed in meter per second (m/s). For a 2/6 minute Walk Test the Test Score is distance in meters. Press the Playback button to review the test. See Figure 7-8. The recorded test run will be replayed from beginning to end.
12. Complete the Assessments section.
13. Press the Save button. See Figure 7-8. **The Save button must be pressed to save test results.** If the button is not pressed before starting another test run or before leaving the screen the current test run results will not be saved to the patient summaries.
14. To save the current test as a baseline, press the Save As Baseline button. See Figure 7-8.
15. To export the current test screen as a screen capture image, press the Export Screen button. See Figure 7-8. When the Export Screen button is pressed, the software saves the test screen as a PNG file and a Save As window will appear. Select the location to save the file.
16. Press the Reset button to clear the previous test results before starting a new test. See Figure 7-2.
17. To view all the of selected Walk test results (5 meters/10 meters/2 minutes/6 minutes) for a given patient, press the View Summary Graph button. See Figure 8-11.

Note: Press the Instruction Guide button to open a window displaying the walking tests instructions from this guide. See Figure 7-8.

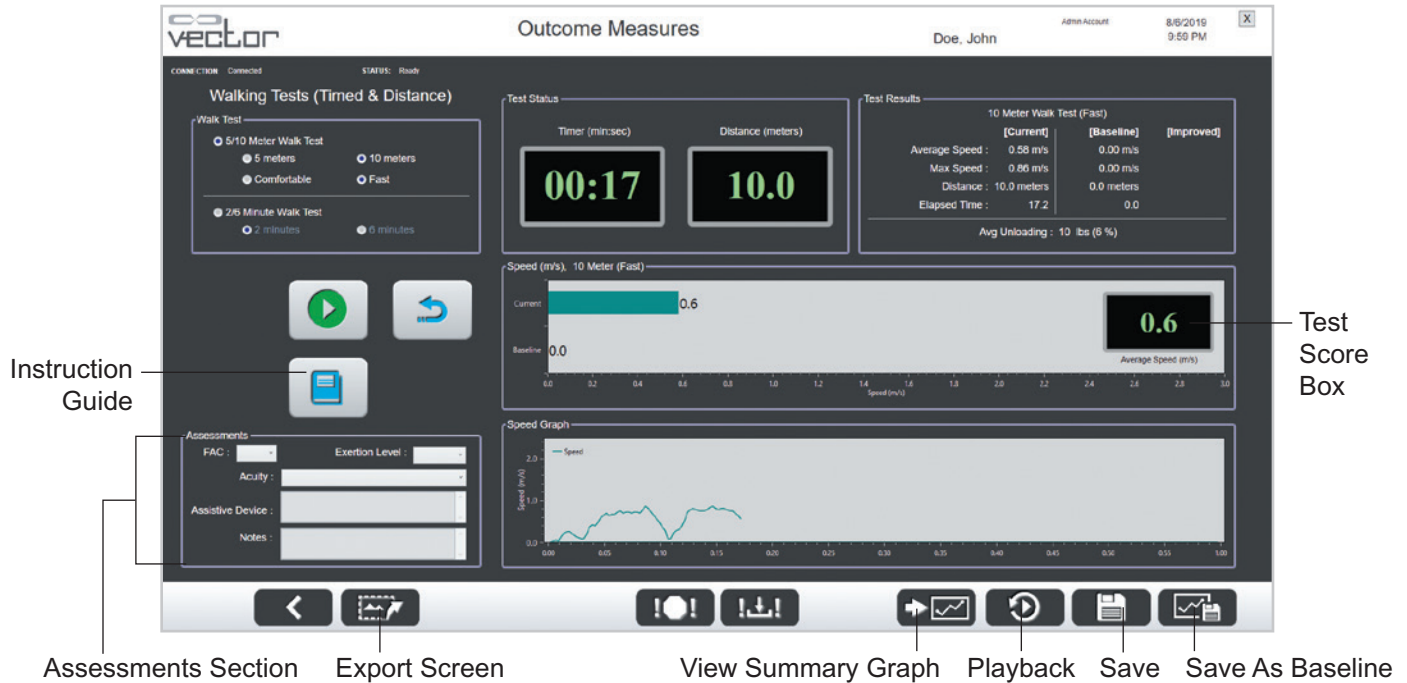

Figure 7-8: Outcome Measures Walking Tests Screen (Test Results, Graphs, and Buttons)

Adjusting Training Controls During an Outcome Measures Test

All of the Training Controls including Trolley Tracking, Dynamic Unloading and the Fall Limit setting can be adjusted while an Outcome Measures test is active.

1. On the active Outcome Measures test screen press the Back button. See Figure 7-7.
2. The software will navigate back to the Training Session screen. The current test type Outcome Measures button will appear in red to indicate that a test is currently recording. See Figure 7-9.
3. Make the desired adjustments to the training controls and press the active Outcome Measures button to return to the Outcome Measures test screen.

Manual Control, Summaries, and Reference Library Menus

The Manual Control, Summaries, and Reference Material Library menus can be accessed from the Main Menu screen. See Figure 8-1.

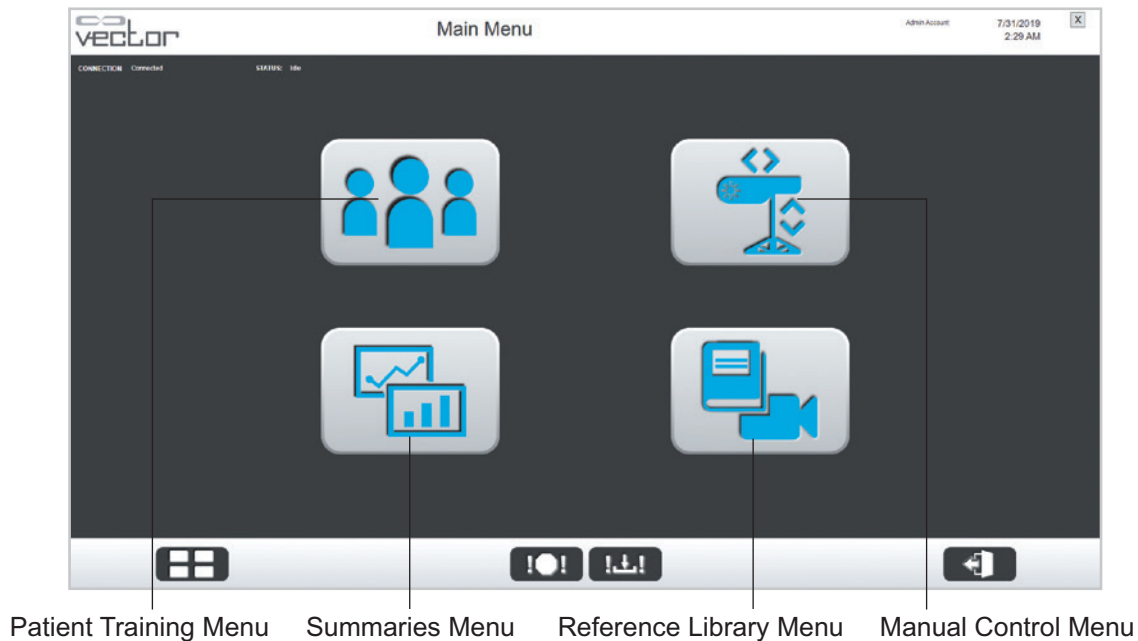

Figure 8-1: Main Menu Screen

Manual Control Menu

From the Main Menu screen, press the Manual Control menu button to open the Manual Control menu. This menu allows the operator to control the trolley manually without needing to select a patient from the patient database. See Figure 8-2. The Manual Control menu should be used for moving the trolley when the user does not need to capture any data.

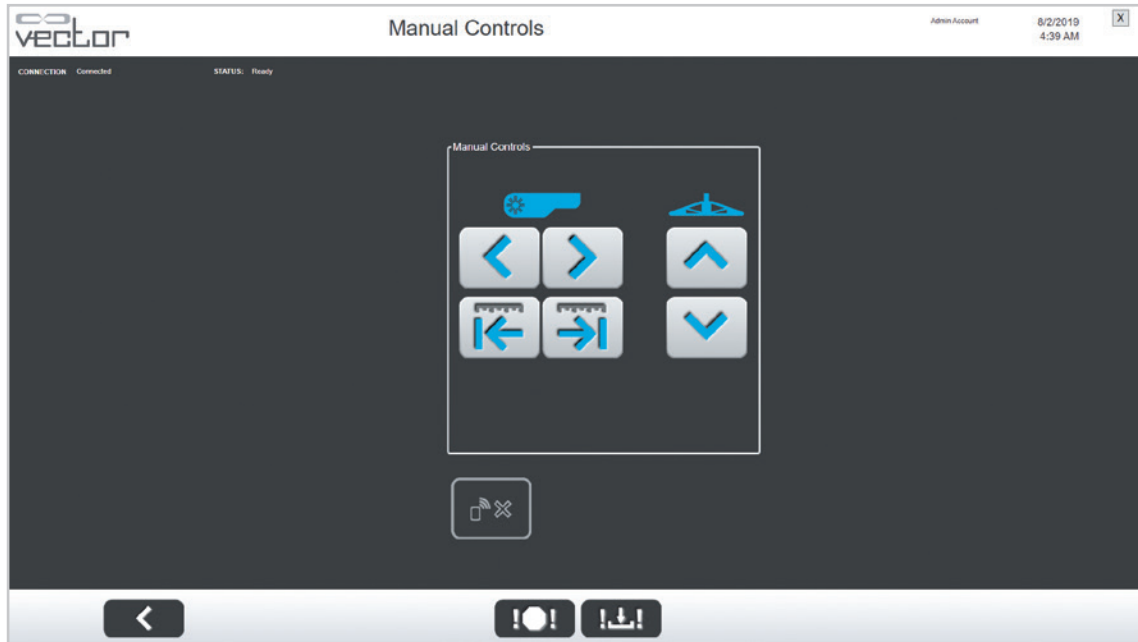

Figure 8-2: Manual Controls Menu

A minimum tension of 0.5 lbs. (0.23 kgs.) must be applied to the rope to manually winch down. This is achieved by allowing the spreader bar to hang freely. This minimum tension prevents damage to trolley hardware pieces including the winch drum, finger guard and rope. If at any time a manual winch down is initiated, or in process, and the minimum tension cannot be detected by the system a warning message window will be displayed. See Figure 8-3.

To continue winching down without the minimum tension of 0.5 lbs. (0.23 kgs.) applied, check the Override box. This enables the winch down button on the popup screen. Once complete, press the X button to continue using the system normally.

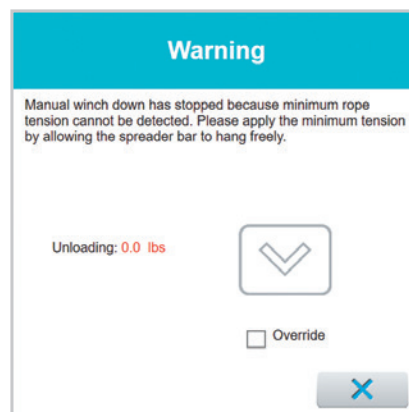
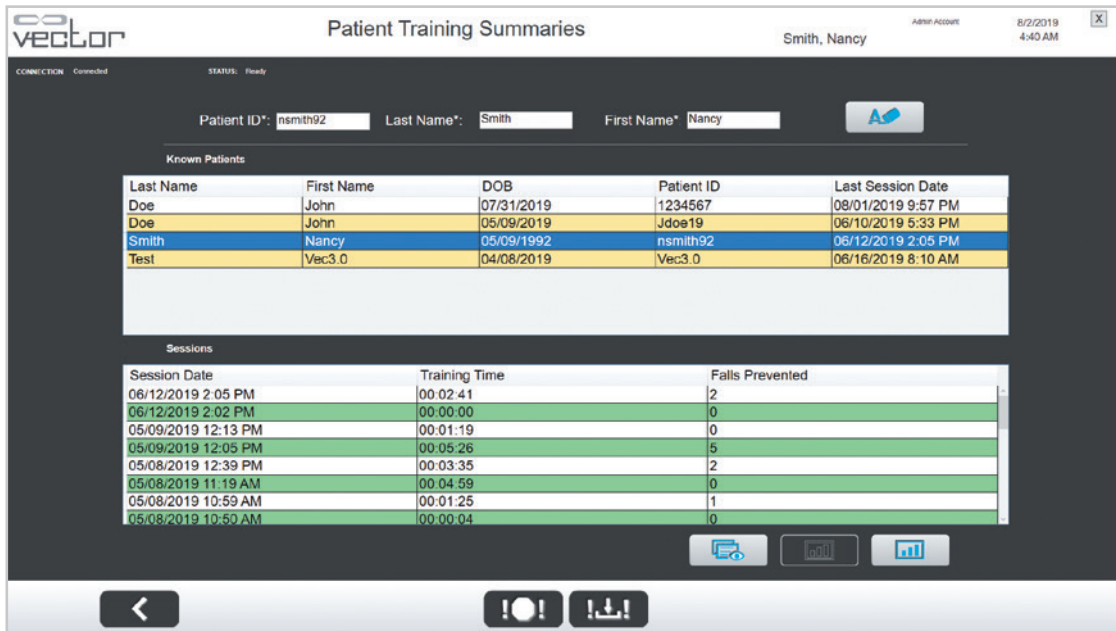

Figure 8-3: Warning Message Window - Minimum Rope Tension

Summaries Menu

1. To open the Patient Training Summaries screen and view training session data from any patient, press the Summaries Menu button on the Main Menu.
2. Once a patient has been selected, a list of their training sessions will appear in the Sessions List. See Figure 8-4.



The screenshot shows the 'Patient Training Summaries' app interface. At the top, it displays the 'VECTOR' logo, the title 'Patient Training Summaries', the user name 'Smith, Nancy', and the date/time '8/2/2019 4:40 AM'. Below this, there are search fields for 'Patient ID*', 'Last Name*', and 'First Name*', with 'nsmith92', 'Smith', and 'Nancy' entered respectively. A 'Known Patients' table lists patient information, with the row for 'Smith, Nancy' highlighted in blue. Below that, a 'Sessions' table lists training sessions with columns for 'Session Date', 'Training Time', and 'Falls Prevented'. The session on '06/12/2019 2:05 PM' is highlighted in green. At the bottom, there are navigation icons for back, home, and search.

Last Name	First Name	DOB	Patient ID	Last Session Date
Doe	John	07/31/2019	1234567	08/01/2019 9:57 PM
Doe	John	05/09/2019	Jdoe19	08/10/2019 5:33 PM
Smith	Nancy	05/09/1992	nsmith92	06/12/2019 2:05 PM
Test	Vec3.0	04/08/2019	Vec3.0	06/16/2019 8:10 AM

Session Date	Training Time	Falls Prevented
06/12/2019 2:05 PM	00:02:41	2
06/12/2019 2:02 PM	00:00:00	0
05/09/2019 12:13 PM	00:01:19	0
05/09/2019 12:05 PM	00:05:26	5
05/08/2019 12:39 PM	00:03:35	2
05/08/2019 11:19 AM	00:04:59	0
05/08/2019 10:59 AM	00:01:25	1
05/08/2019 10:50 AM	00:00:04	0

Figure 8-4: Sessions List

3. To view data from a single training session, select the session date from the list and press the Single Training Session Summary button. See Figure 8-5.

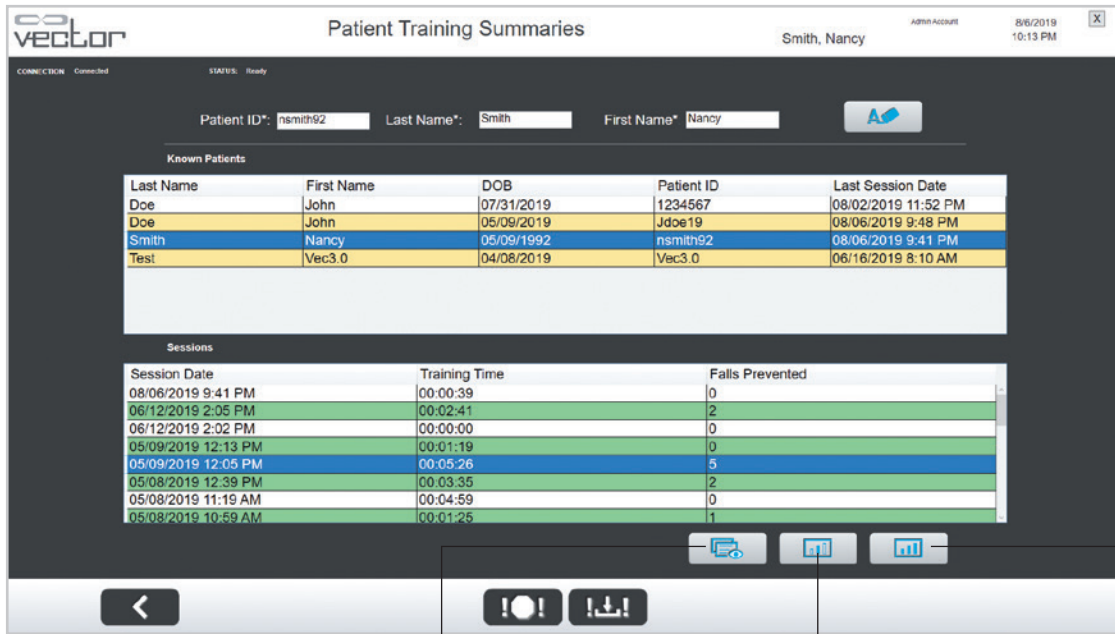

Outcome Measure Single Training Session Summary Training History

Figure 8-5: Patient Training Summary

4. This displays the Session Summary, including the average speed and total distance traveled. From the Session Notes section, record the activities performed, assistive device used, level of exertion and any comments related to the training session.
5. Press the Save button to save any session notes that were entered.
6. Press the Save PDF Report button to save the selected summary as a PDF.

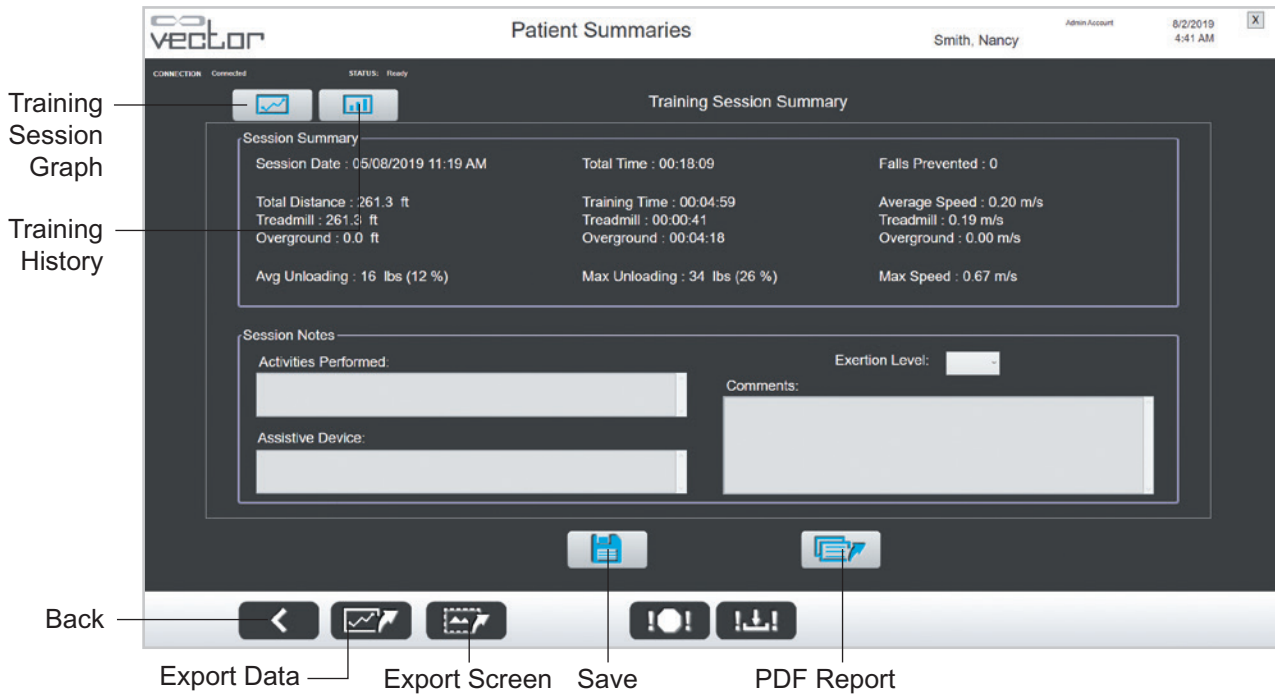

Figure 8-6: Training Session Summary

- From the Training Session Summary screen, press Training Session Graph. See Figure 8-6. This displays the summary in graph format. See Figure 8-7.

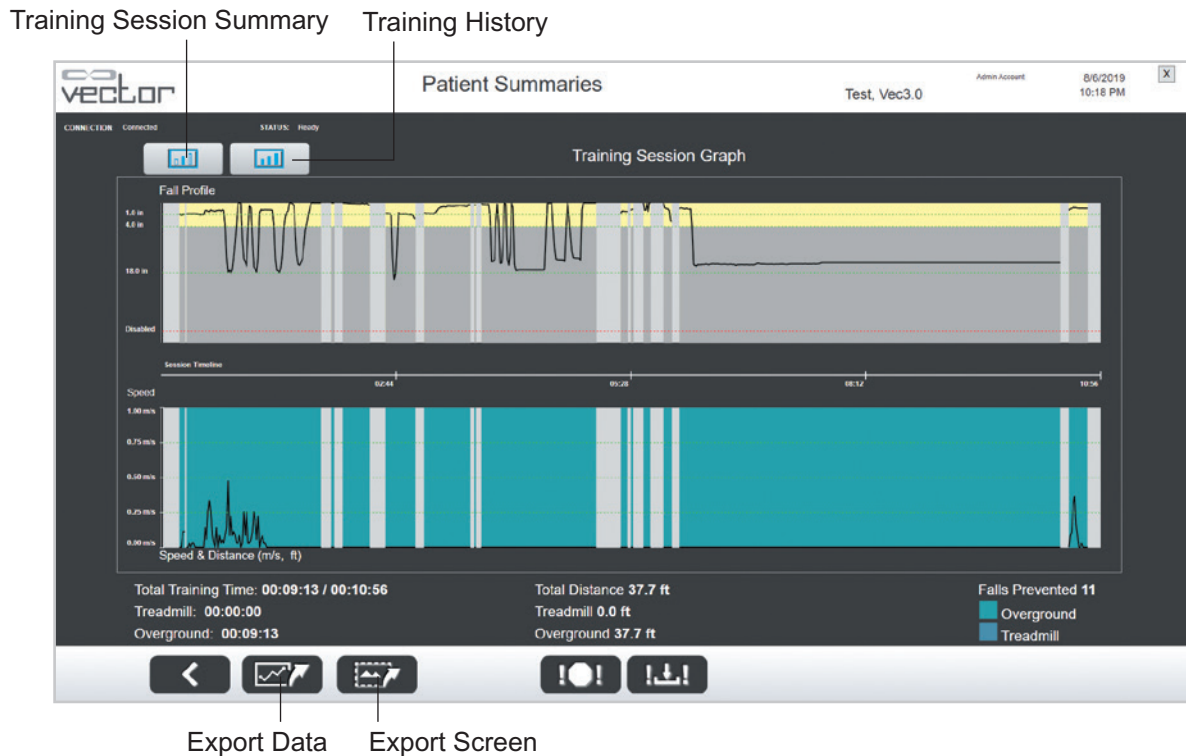

Figure 8-7: Training Session Graph

- To go back to the Training Session Summary screen, press the Training Session Summary button.
- To go to the Training History screen, press the Training History button. See Figure 8-8.
- You can access the Training History screen from the Patient Training Summaries screen, by selecting a patient from the Known Patients list and press the Training History button. You'll see the results (as bar graphs) from multiple sessions for the selected patient.

Training Session Summary



Figure 8-8: Training History (for Outcome Measures Software Module)

11. If your system features the Outcome Measures software module, you will see an Outcome Measures Summary button on the Patient Training Summaries screen. See Figure 8-9.

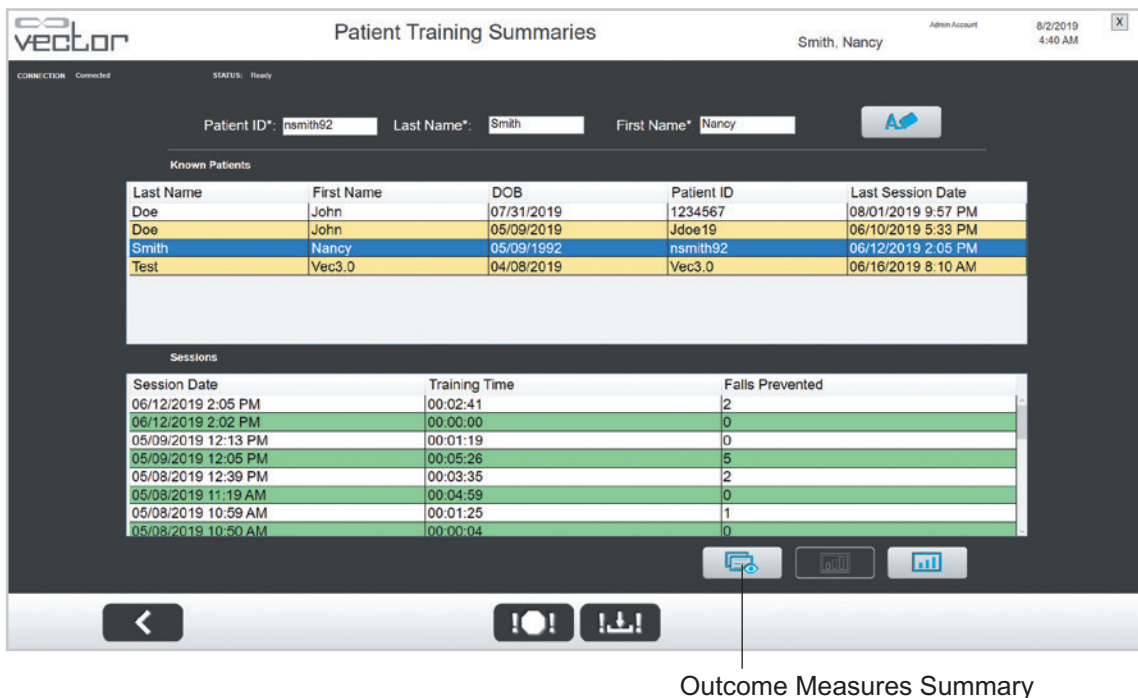

Figure 8-9: Outcome Measures Summary

12. From the Patient Training Summaries screen, select a patient from the Known Patients list and press the Outcome Measures Summary button. See Figure 8-10.
13. The Outcome Measures Summary screen displays list of saved test runs, organized under tabs for TUG, 10 Meter Walk, 5 Meter Walk, 6 Minute Walk, and 2 Minute Walk. Navigate to a tab and select a single test run to view test results. See Figure 8-10.











Button	Definition
 Back Button	Takes the user back to the previous screen.
 Export Data Button	Exports the session data as an excel document (CSV file). When the Export Data button is pressed, the software exports the data and a Save As window will appear. Select the location to save the file and press the Save button.
 Export Screen Button	Exports the current graph as a screen capture image. When the Export Screen button is pressed, the software saves the graph that is displayed on the screen as a PNG file and a Save As window will appear. Select the location to save the file and press the Save button.
 Main Menu Button	Takes the user to the Main Menu screen.
 Save As Baseline Button	Saves the currently selected test run as the Baseline Test for that test type (organized by tab). Button is located on the Outcome Measures Summary screen.
 Save Button	Saves the updated assessments including FAC, acuity, exertion level, assistive device.
 Playback Button	Takes the user to a new window displaying a TUG or Walking Tests screen where the selected test run will be played back. Press the Back button on the Playback screen to leave Playback Mode. Playback button is located on the Outcome Measures Summary screen.
 Export Report Button	Exports a PDF report containing the results, assessments, and comments for the currently selected test run. When the Export Report button is pressed, the software saves the report as a PDF file and a Save As Window will appear. Select the location to save the file and press the Save button. Button is located on the Outcome Measures Summary screen.
 Outcome Measures Graph Button	Takes the user to the Outcome Measures Graph screen for the test type (tab) that is currently selected. Button is located on the Outcome Measures Summary screen.
 Logout Button	Takes the user back to the Login screen.

Table 8-2: Button Definition

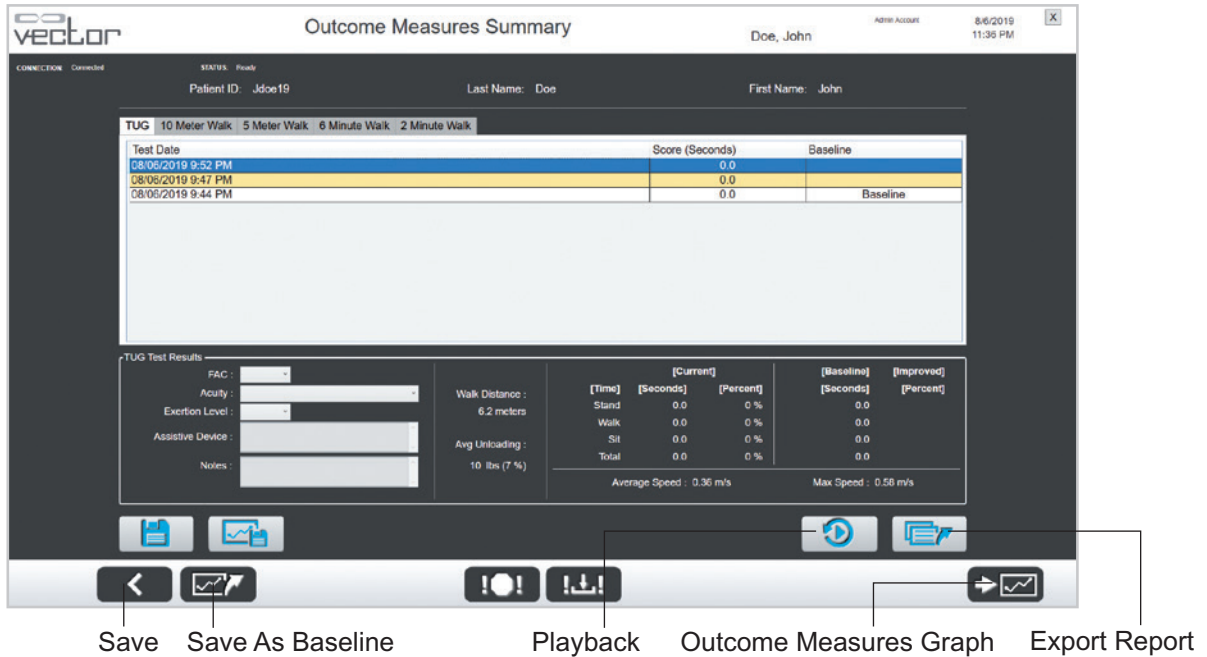

Figure 8-10: Outcome Measures Summary Screen

- From the Outcome Measures Summary screen, press the Outcome Measures Graph button. See Figure 8-9. The Outcome Measures Graph screen will open for the test type (tab) that is currently selected. The graph will display key results of multiple test runs over a selected number of tests. The graph will also display the Baseline score and daily average (summary). See Figure 8-11.
- You can select to view data from the last 10, 30, or all sessions, via drop-down menu labeled "Last Sessions."

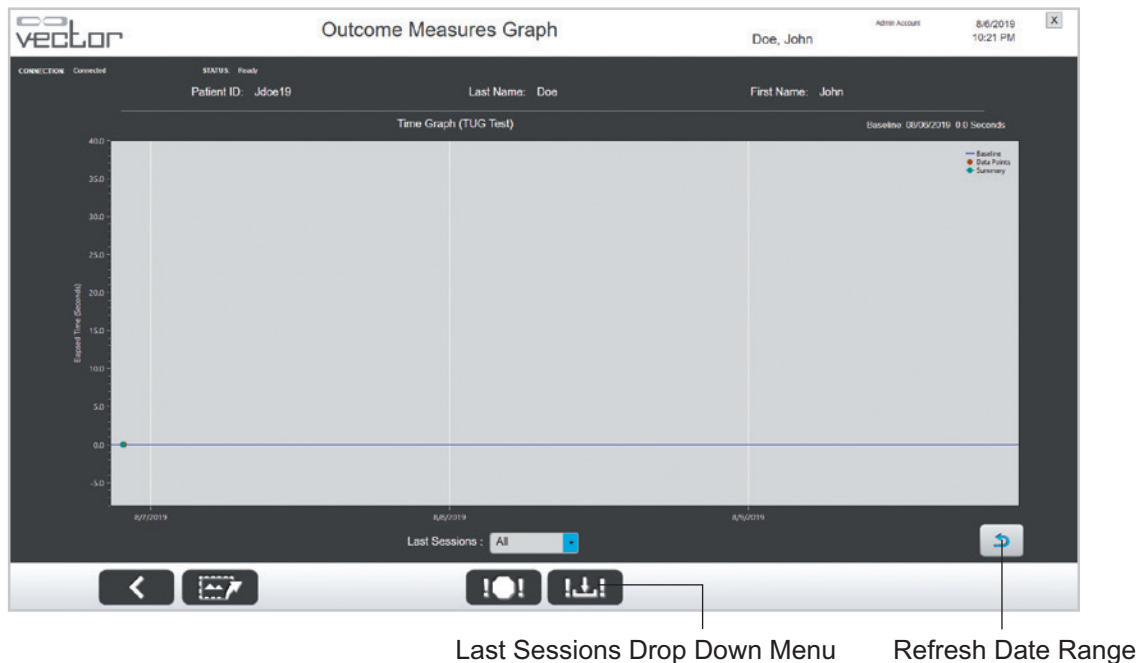

Figure 8-11: Outcome Measures Summary Graph

Reference Library Menu

From the Main Menu screen press the Reference Library Menu button to open the Reference Library Menu screen. See Figure 8-12. Press the Training Videos button to access a folder where training videos are stored. Press the Instruction Guide button to access an electronic version of the clinician guide.

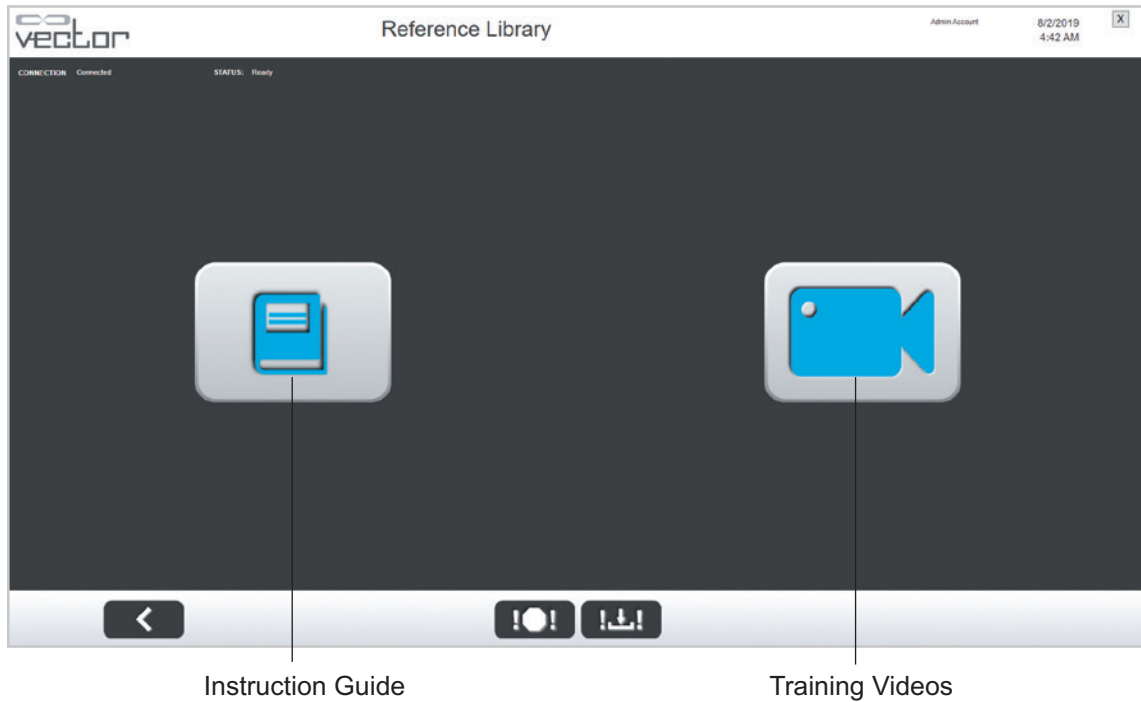

Figure 8-12: Reference Library Menu Screen

Vector Elite Remote Control

The remote control has a large subset of the Vector Elite PC capabilities. The remote control is a Samsung Galaxy S6 (or equivalent) with the Vector Elite software application. The remote control is an accessory device that is not required to operate the Vector Elite system, but does it provide convenience for the user. The remote control allows the user to operate the Vector Elite system, while being able to be next to the patient during a training session.

Note: The remote control has not been evaluated by UL and is not covered under the UL Classification of the Vector Elite system.

Starting the Vector Elite Remote Control

1. Turn on the Vector Elite remote control.
2. To launch the Vector Elite software, press the Vector Elite software application icon, on the remote control home screen.

Vector Elite Remote Control

Vector Elite Remote Control Software Screens

The Vector Elite remote control software application contains seven tabbed screens. These can be accessed using the scrolling tab menu at the top of the user interface. The four main control screens are Manual Controls, Training Controls, Advanced Training, and Take Control. See Figure 9-1. In addition to these control screens, the remote control software includes one screen dedicated to providing Session Status and two additional screens for the Outcome Measures module.



Figure 9-1: Manual Controls, Training Controls, Session Status, and Take Control Screens

Manual Control Screen

When the Remote Control Vector Elite Software Application is launched the Manual Controls screen will open. The remote control buttons allow the user to winch the rope up and down and to move the trolley along the track in either direction.

A minimum tension of 0.5 lbs. (0.23 kgs.) must be applied to manually winch down the rope. This is achieved by allowing the spreader bar to hang freely. This minimum tension prevents damage to trolley hardware pieces including the winch drum, finger guard, and rope. If at any time a manual winch down is initiated, or in process, and the minimum tension is not detected, you will see a warning message. See Figure 9-2.

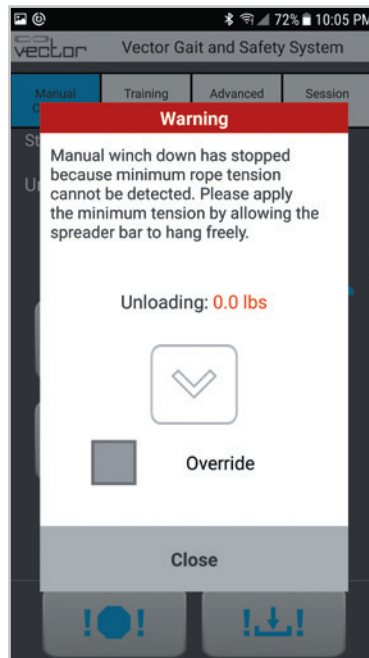

Figure 9-2: Remote Control Warning Message Window

Once the minimum tension of 0.5 lbs. (0.23 kgs.) or more has been applied by allowing the spreader bar to hang freely, the amount of unloading will be displayed in green. Press Close to exit out of the warning message window and continue to winch down.

If you must continue winching down without the minimum tension of 0.5 lbs. (0.23 kgs.), check the Override box to enable the winch down button on the popup screen. Once complete, press Close, and continue using the system normally.

Training Controls Screen

The Training Controls screen is used to activate and/or deactivate the Trolley Tracking and Dynamic Body Weight Support (DBWS). The screen is also used to adjust the Fall Prevention setting and the Dynamic Unloading setting.

Status Screen

The Session Status screen displays information for the current training session, including the unloading value, training time of the session, distance traveled, and number of prevented falls. The system unit settings and software version can also be accessed from this screen by pressing the Settings button. To look up the software version press the Reference button.

Take Control Screen

The Take Control screen transfers control of the Vector Elite system from the PC to the remote control.

Press the Take Control button to transfer control from the PC to the remote control. See Figure 9-3. Once control has been transferred, the Take Control button on the remote control will be disabled and the Training Controls buttons will be enabled.

The Connect Treadmill button is also located on the Take Control screen. Press the Connect Treadmill button to connect with a compatible treadmill and control it from the Remote Control

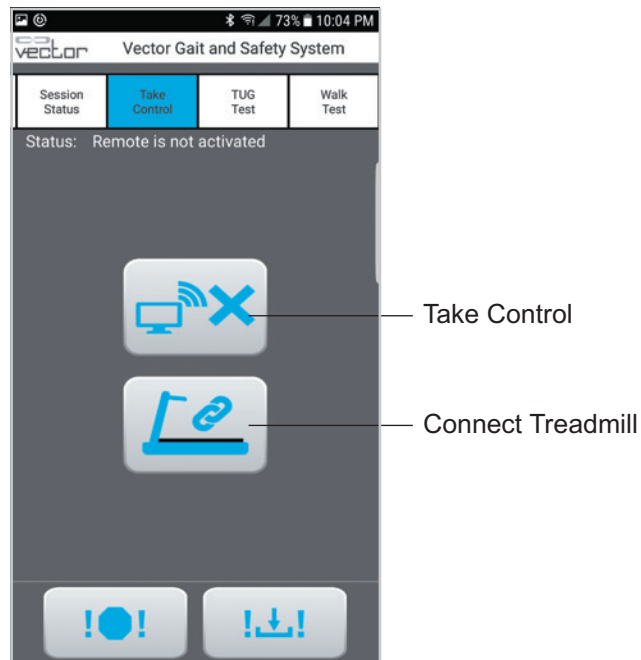

Figure 9-3: Take Control Screen

Treadmill Controls Screen

The Treadmill Controls screen is used to remotely start, stop, and modify settings of the treadmill from the Remote Control. This screen is displayed only after connecting a compatible treadmill via the Take Control Screen. See Figure 9-4.

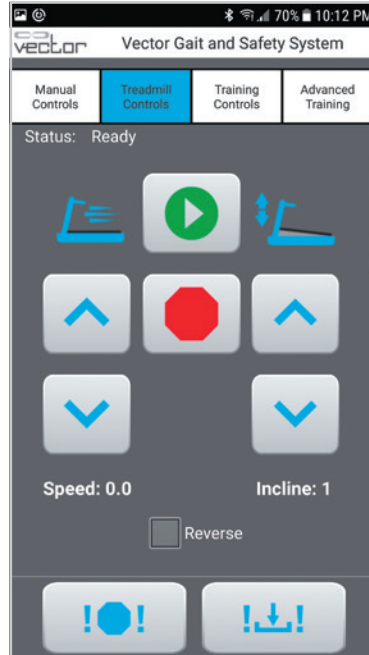

Figure 9-4: Treadmill Controls Screen

Remote Control Outcome Measures

For Vector Elite systems that feature the Outcome Measures software module, the remote control also features two additional software screens, as well as the four screens discussed in the previous section of this chapter. The remote control can be used to start and stop an Outcome Measures test and will display a subset of the data collected during the test.

To access the Outcome Measures software screens, swipe left or right on the Vector remote control software tabs. Two additional tabs, TUG Test and Walk Test, will appear on the right side of the screen. See Figure 9-5.

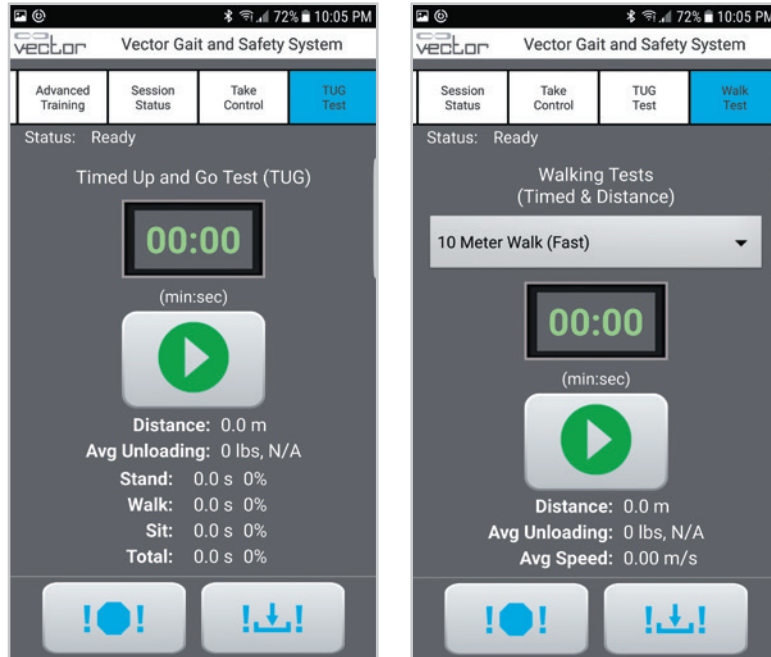

Figure 9-5: Remote Control TUG Test and Walking Tests Screens

Controlling Device Status

Only one device (PC or remote control) can be in control of the Vector Elite system at any given time. This is a safety feature designed to prevent conflicting commands from being issued. Both devices display on the screens whether they are or are not in control. To ensure that only one device is in control, the buttons on the device will only be active (enabled) if that device is in control. See Figure 9-6.

In order to transfer control from one device to the other, the non-controlling device must take control by pressing the Take Control button. See Figure 9-7. The exceptions to this rule are the Emergency Stop and Emergency Lower buttons. If a compatible treadmill is connected to the Vector software, the treadmill controls is also an exception. These buttons will remain active on both PC and Remote Control at all times. The device that is not currently in control will display a message that the other device is in control. See Figure 9-8.

For Vector Systems that feature the Outcome Measures software module, the Remote Control can start or stop an Outcome Measures test regardless of which device (PC or remote control) is in control of the Vector Elite system. For example, if the PC is in control of the system, an Outcome Measures test can be started or stopped from the Remote Control. Any adjustments to the Training Controls during the Outcome Measures test will still only be accessible by the device that is in control.



Figure 9-6: Example of Status Displays for Remote Control (Left) Remote Is Not In Control of Trolley, (Right) Remote Is In Control of Trolley



Figure 9-7: Location of Take Control Button, PC (Left) and Remote Control (Right)

If the controlling device loses communication with the Vector Elite trolley, the trolley will automatically transfer control to the other device. For example, if the remote control battery dies while in use, the trolley will automatically transfer control to the PC. If both the PC and the remote control lose communication with the trolley, then the trolley enters a safe state where both motors stop moving until a recognized device is in control again.

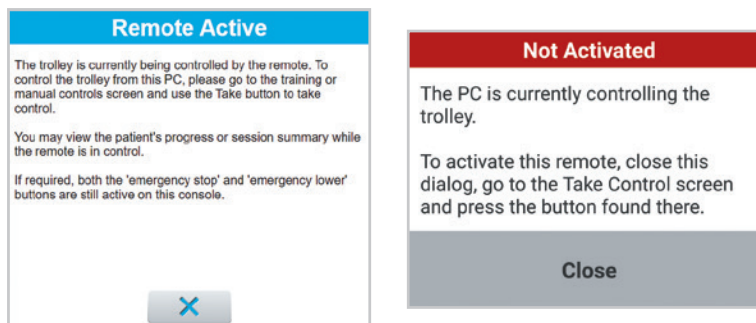

Figure 9-8: Message Window on PC (Left) and on Remote Control (Right)

Using the Remote Control for a Patient Training Session

A patient training session has to always be started from the PC in order for the Vector Elite system to capture patient data.

1. Select a patient from the Patient Menu screen. See “Patient Training Menu” section of this guide.
2. Press the Start Training button to open the Training Session screen. See “Training Session Screen” section of this guide.
3. Turn on the remote control, press the Take Control tab.
4. To transfer system control from the PC to the remote control, press the Take Control button
5. Once the remote control establishes connection with the Vector Elite trolley the status display will state “Ready” and the Take Control button will be disabled.
6. Press the Training Controls tab.
7. If needed, adjust the Dynamic Unloading setting and/or Fall Limit setting.
8. Press the Trolley Tracking and/or DBWS buttons to start the patient training session.

Adjusting the Dynamic Unloading Value During a Training Session:

The Dynamic Unloading value can be adjusted while the DBWS feature is active.

1. To adjust the Dynamic Unloading setting, use the up arrow button to increase or the down arrow button to decrease the amount of unloading. The new setting will appear in the text between the buttons. The adjustment will be instantaneous and will take effect while the patient is actively training.

Changing Fall Prevention Mode During a Training Session

The Fall Prevention mode can be changed during a training session.

1. Use the Fall Prevention drop-down menu. Distance, Active Body Control, or Disabled. The Save button will turn red. See Figure 9-9.
2. Press the Save button.



Figure 9-9: Fall Prevention Menu

Note: You must press the Save button to enable the new Fall Prevention model.

Adjusting the Fall Limit Value During a Training Session:

In Distance Fall Prevention mode, the Fall Limit can be adjusted while the DBWS and/or Trolley Tracking features are active.

1. To adjust the Fall Limit value, use the up arrow button to increase or the down arrow button to decrease the amount. The new setting will appear in red text between the buttons and the Save button will turn red.
2. Press the Save button. The text between the buttons and the Save button will turn green.

Note: You must press the Save button to activate the revised Fall Limit.

Changing the Assistance Level During an Active Body Control Session

Active Body Control uses force measurements to determine if a fall has occurred. This mode provides three: minimum, moderate and maximum.

1. To change the Active Body Control Assistance Level, use the drop-down menu to select minimum, moderate or maximum. See Figure 9-10. The Save button will turn red.
2. Press the Save button.

Note: You must press the Save button to enable the new Assistance Level.

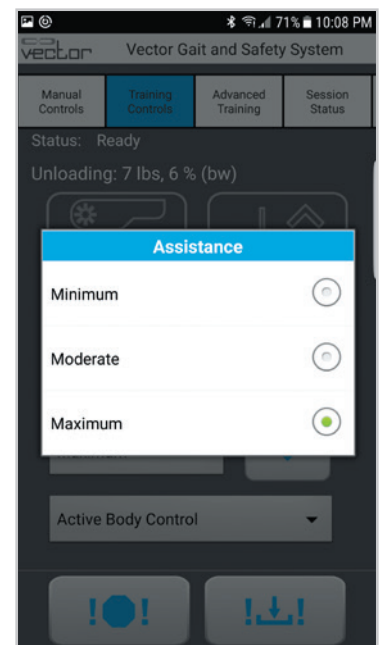



Figure 9-10: Assistance Level

Disabling the Fall Limit

You can also use the remote control to disable the Fall Limit.

1. Select Disabled from the pull-down menu.
2. Press the Save button.

Note: The Save button turns red when the Fall Prevention mode is changed.

 **Caution:** Patient injury could occur when the Fall Limit is disabled, so use extra caution.

Fall Prevention

When a fall is prevented, the trolley locks and goes into Static Unload mode.

1. When the Vector Elite system detects a fall, the Fall Prevented window appear. See Figure 9-11.
2. Press the Winch Up button, to return the patient to standing position. You can also use the Emergency Lower button to lower the patient to the ground.
3. Press the Close button to close the Fall Prevented window. If the patient is in standing position, press the DBWS button and (if applicable) the Trolley Tracking button to resume the training session. There must be at least 10 lbs. (4.5 kgs.) of unloading on the system to activate DBWS or Trolley Tracking.

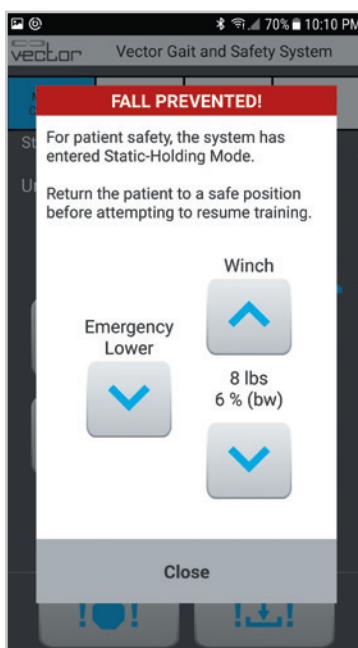

Figure 9-11: Fall Prevention Dialog Box

Auto Recovery

To enable or disable Auto Recovery, use the remote control to access the Manual Controls screen. See Figure 9-3. With auto recovery enabled, if a fall is detected while Auto Recovery is enabled, the system will maintain rope tension allowing the patient to self-correct and stand up without assistance and resume the session.

A Fall Prevention window will be displayed indicating that Auto Recovery is in progress. See Figure 9-12.

1. Allow the patient to self-correct and stand up without assistance.
2. When the patient reaches the original standing position, Trolley Tracking and DBWS will resume their normal operation automatically.
3. The clinician can cancel the Auto Recovery feature at any time by pressing the manual winch up or down button on the Fall Prevention window. See Figure 9-12.

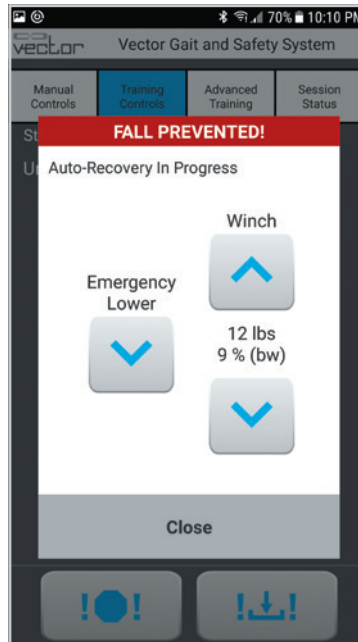

Figure 9-12: Auto Recovery Dialog Box

Using the Remote Control with an Integrated Treadmill

A compatible treadmill can be controlled from the Remote Control after it is connected to the Vector software.

1. Ensure that the treadmill is powered on and plugged into the PC using the cables provided. For more information on cable connection, see Page 31.
2. In the Vector PC software, add or select a patient and start a training session. For more information on starting a Training Session, see Pages 13-14.

Note: The treadmill cannot be connected until a Training Session is initiated through the Vector PC software.

3. In the Vector Remote Control application, navigate to the Take Control screen and press the Connect Treadmill button. See Figure 9-13.

Note: Connecting the treadmill using the Remote Control does not give control of the Vector System to the Remote Control. The Take Control button must also be selected in order to control Vector from the Remote Control.

Note: If the treadmill is not correctly connected to the PC and powered on, an error will be displayed. See Figure 9-14.

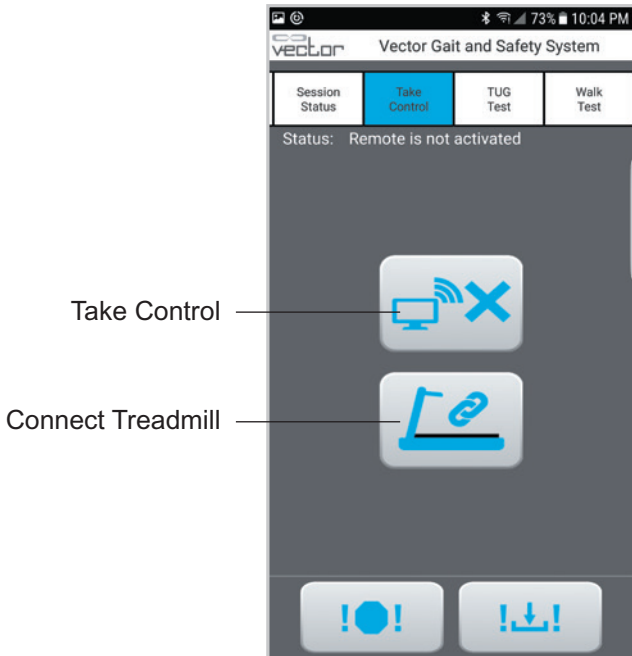

Figure 9-13: Take Control Screen

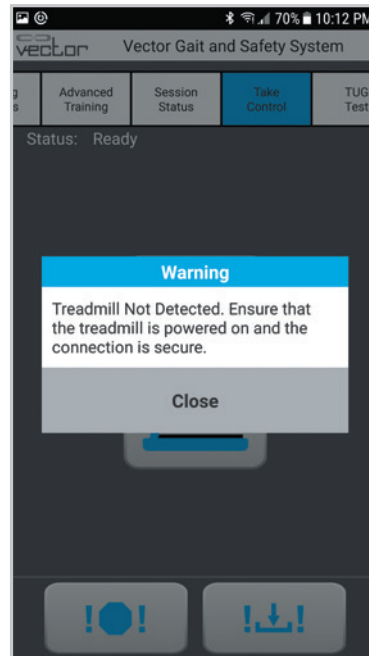

Figure 9-14: Treadmill Connection Error

4. After connecting the treadmill, the Treadmill Controls screen will be activated, and a training session can be initiated using the Start button. See Figure 9-15.

Note: If the system does not detect a minimum of 10 pounds on the spreader bar, an error will be displayed and the treadmill will not start. See Figure 9-16.



Figure 9-15: Treadmill Controls Screen

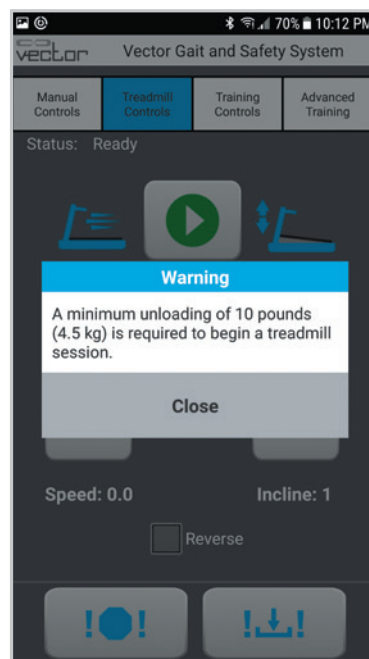

Figure 9-16: Minimum Loading Error

5. When the treadmill is active, the Start button will be replaced by the Pause button which can be used to pause the treadmill session as needed.
6. The Up and Down arrow buttons can be used to adjust speed and incline.
7. The belt direction can be reversed by pausing the treadmill session, then selecting the Reverse check box. See Figure 9-17.

Note: The belt direction cannot be changed while the treadmill belt is in operation, and the Reverse checkbox will not be enabled for selection until the treadmill session is paused.

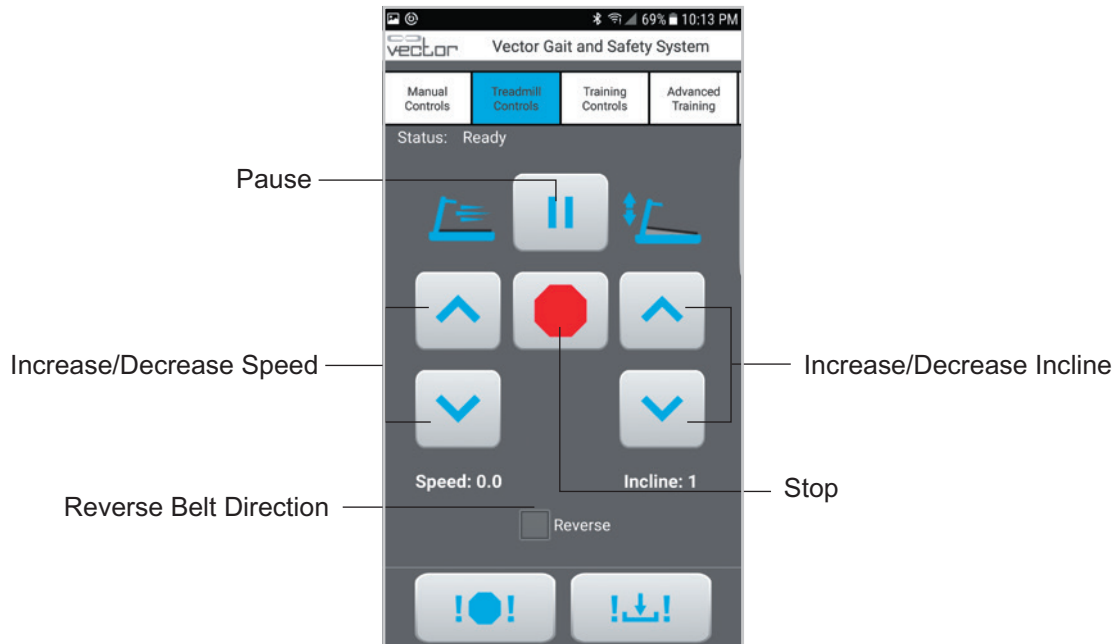

Figure 9-17: Treadmill Controls Screen with Treadmill On

8. When a fall is detected, the treadmill will stop automatically and the treadmill controls will be disabled until the Fall Prevented dialog box is closed. See Figure 9-18.

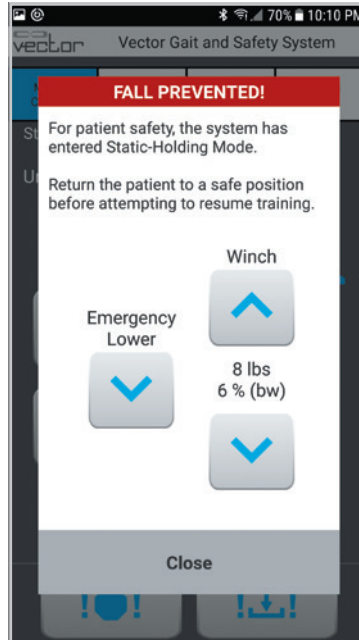

Figure 9-18: Fall Prevented Dialog Box

9. To end the treadmill session, press the Stop button and select Disconnect on the dialog box. See Figure 9-19.

Note: After the Stop button is selected, the previously used treadmill settings will be cleared, even if the Cancel button is selected on the dialog box.

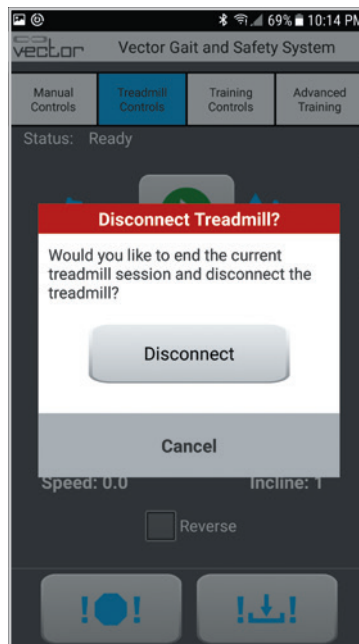

Figure 9-19: Disconnect Treadmill Confirmation Dialog Box

Using the Remote Control for an Outcome Measures Test

To capture patient data, a training system must be started from the PC.

Please refer to Chapter 6, Vector Outcome Measures.

TUG Test

1. On the remote control, select the Take Control tab and press the Take Control button.
2. Select the TUG Test tab.
3. Press the Start button on the Timed Up and Go Test (TUG) screen. See Figure 9-20.
4. During the TUG Test training controls can be adjusted. Swipe back to the Training Controls tab.
5. Make the desired adjustments to the training controls. Swipe to the right on the tabs and select the TUG Test tab to return to the TUG screen.

Note: The training controls are only accessible by the device that is in control.

6. Once the patient is seated, press the Stop button to end the test. See Figure 9-21.
7. Return to the PC to review test results, fill in assessments, and save the test. The test can also be saved as a baseline or exported as a screen capture from the PC.

Note: To save the test results, you must press the Save button on the PC.



Figure 9-20: TUG Start Screen

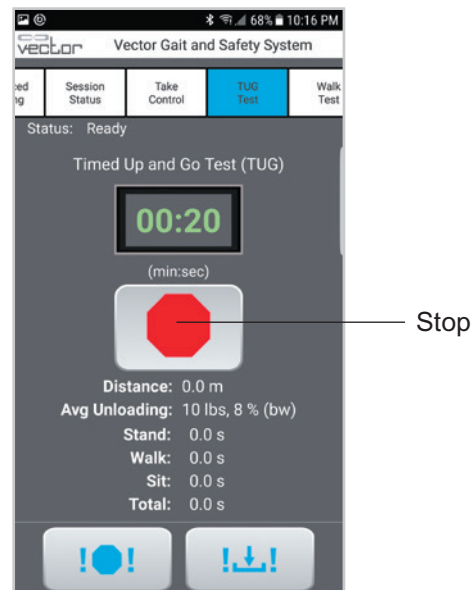

Figure 9-21: TUG Stop Screen

Walk Test

1. On the remote control, select the Take Control tab and press the Take Control button.
2. On the remote control, select the Walk tab.
3. From the Walking Test screen, use the drop-down menu to choose the appropriate test:
 - 5 meter, fast
 - 5 meter, comfortable
 - 10 meter, fast
 - 10 meter, comfortable
 - 6 minute
 - 2 minute
4. **For the 5 or 10 Meter Walk Test:** When the patient has accelerated to their comfortable/fast walking pace, press the Start button. See Figure 9-22. If you have placed markers, press the Start button when the patient's front foot crosses the 2-meter mark.
 - The test collection will continue and automatically stop when a distance of 5 or 10 meters has been walked. Instruct the patient to stop walking.
5. **For the 2 or 6 Minute Walk Test:** Press the Start button when the patient begins to walk. The patient must continuously walk as far as possible during a 2 or 6 minute period.
 - The test collection will continue and automatically stop when a time of 2 or 6 minutes has been reached. Instruct the patient to stop walking.
6. To adjust the training controls during a Walking Test, swipe back to the Training Controls tab.
7. Make the desired adjustments to the training controls. Swipe to the right on the tabs and select the Walk Test tab to return to the Walking Test screen.

Note: The training controls are only accessible by the device that is in control.

8. The test will automatically stop at the selected distance or time. To cancel the test at any time, use the Stop button. See Figure 9-23.
9. Return to the PC to review test results, fill in assessments, and save the test. The test can also be saved as a baseline or exported as a screen capture from the PC.

Note: To save the test results, you must press the Save button on the PC.

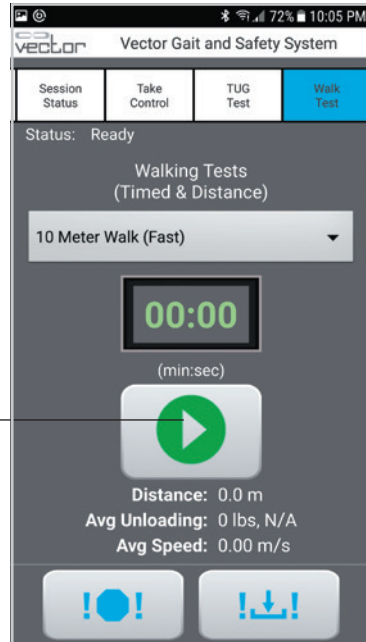

Figure 9-22: TUG Start Screen

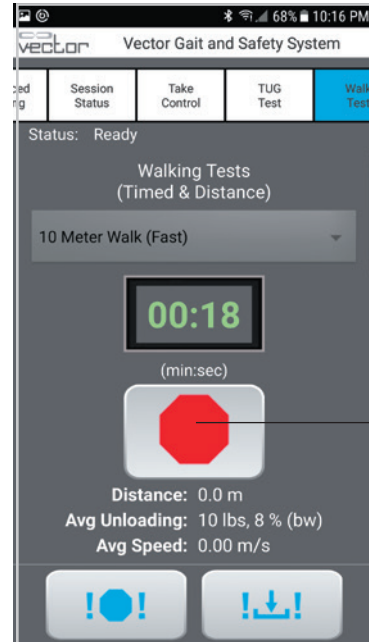

Figure 9-23: TUG Stop Screen

Emergency Stop and Emergency Lower

Use the remote control to press the Emergency Stop button or the Emergency Lower button at any time. When the Emergency Stop button is pressed the trolley stops moving and locks in position. When the Emergency Lower button is pressed, the system will continue to winch down the rope until the patient has reached the ground or until the rope tension goes below the minimum unload value.

Using the Remote Control to Operate System Without Patient Data

When powering on the Vector Elite system, if the remote control establishes a connection with the trolley before the PC does, the training data will not be saved. A patient account must be selected from the PC for training data to be saved.

To control the Vector Elite system without capturing training data:

1. Turn on the Vector Elite trolley and then turn on the remote control to establish a connection.
2. If the Trolley Tracking and/or DBWS buttons are pressed, without the PC establishing connection to the trolley or a patient account being selected and a training session initiated from the PC, then you will see a warning message stating, "Training data is currently not being saved." Press the OK button to proceed with using the remote control. See Figure 9-29.

Advanced Training

The Advanced Training screen is used to enable Intuitive Body Weight Support And Trolley Cue features. Detailed descriptions of these features are available in the Patient Training Screen section of this guide.

Intuitive Body Weight Support

Gait Smoothing and Ascent Assist can be enabled independently or simultaneously with each other. For these features to operate, DBWS must be enabled from the Training Controls screen.

Gait Smoothing: To enable the Gait Smoothing feature, begin a Training Session while logged in with the correct Patient Profile. Alternatively, the patient weight may be entered with the Vector Remote, but it must be entered every time Gait Smoothing is enabled.

1. Select the Advanced tab to display the Intuitive Body Weight Support controls. The Gait Smoothing button will be displayed.

Note: Gait Smoothing can be enabled independent of DBWS and Trolley Tracking.

2. Press the Gait Smoothing button to enable it. When Gait Smoothing is enabled, the button will turn red. See Figure 9-24.
3. When finished with the Gait Smoothing feature, press the red Gait Smoothing button to disable it. When disabled, the button will turn green again.

Note: Gait smoothing will remain enabled until it is manually disabled, even if DBWS is not enabled.

Ascent Assist: To enable the Ascent Assist feature, begin a Training Session while logged in with the correct Patient Profile. Alternatively, the patient weight may be entered with the Vector Remote, but it must be entered every time Ascent Assist is enabled.

1. Select the Advanced tab to display the Intuitive Body Weight Support controls. The Ascent Assist button will be displayed.
2. Ensure DBWS is enabled and that the patient is standing, and press the Ascent Assist button.
3. A popup message will be displayed with instructions for verifying patient weight and ensuring that the patient is standing. If the displayed weight is incorrect, it must be updated prior to using this feature. See Figure 9-25.

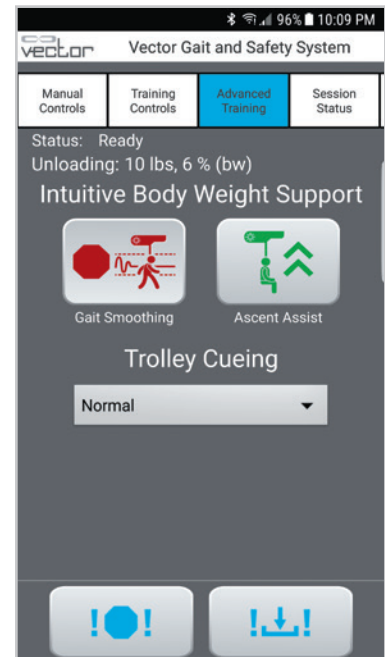

Figure 9-24

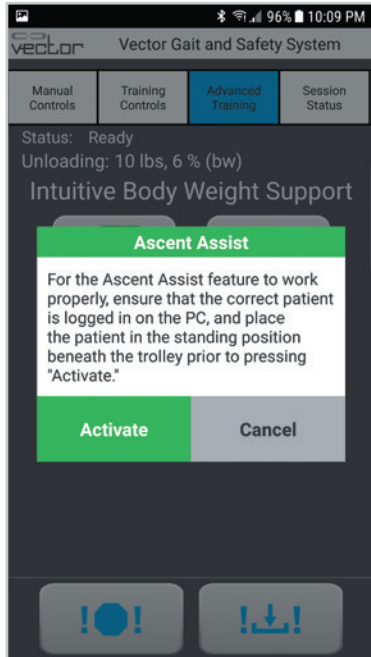

Figure 9-25

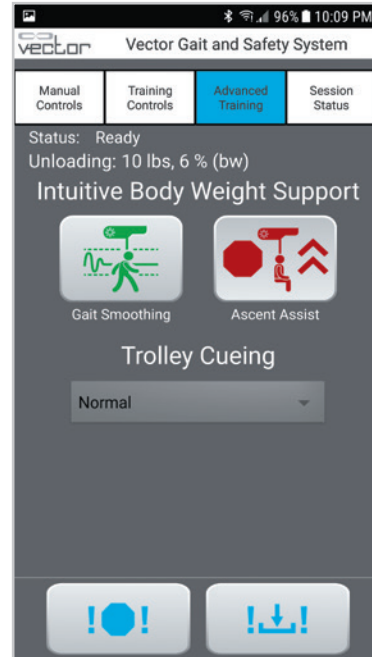

Figure 9-26

4. When Ascent Assist is enabled, the button will turn red. See Figure 9-26.
5. When finished with the Ascent Assist feature, press the red Ascent Assist button to disable it. When disabled, the button will turn green again.

Trolley Cue

Posterior Cue & Anterior Cue: Cuing can be enabled using the Vector Remote. Adjustments including disabling Homing or changing the Cue Angle can be made using the Vector PC.

1. Select the Advanced Training tab to display the Trolley Cue controls. The Cuing drop-down will be displayed.
2. Open the drop-down menu and select the Posterior Cue or Anterior Cue mode. See Figure 9-27.
3. Select Normal to disable the Trolley Cue and return to normal Trolley Tracking.

Note: The Homing option is enabled when the Vector Remote is in use without the Vector PC.

Anterior Chase: To enable Anterior Chase, begin a Training Session while logged in with the correct Patient Profile. Alternatively, the patient weight may be entered with the Vector Remote, but it must be entered every time Ascent Assist is enabled.

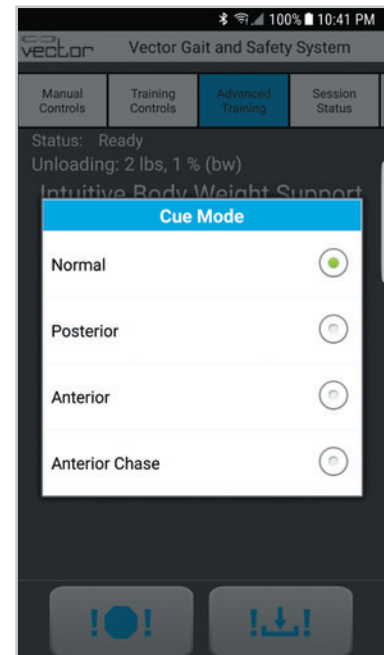

Figure 9-27

1. Select the Advanced Training tab to display the Trolley Cue controls. The Cuing drop-down menu will be displayed.
2. From the drop-down menu, select Anterior Chase.
3. Set the target speed by pressing the arrow buttons. See Figure 9-28.

Note: The target speed can be adjusted at any time, including before and after the patient begins walking.

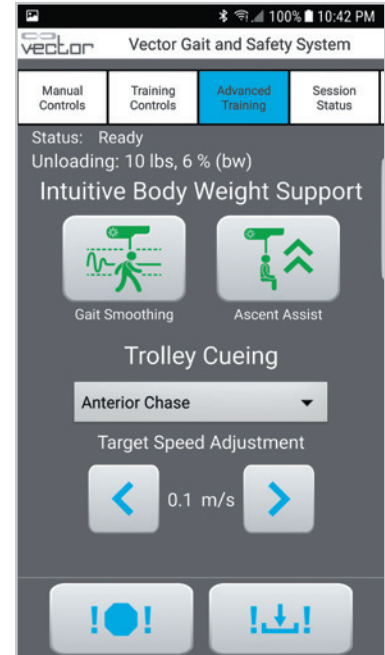

Figure 9-28

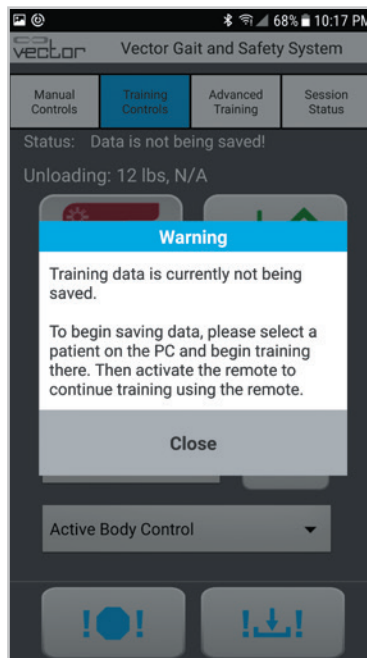

Figure 9-29: Warning Message - Training Data Not Being Saved

Charging the Remote Control

The remote control should be charged daily. Use the supplied AC adaptor and/or the micro USB cable for charging.

Multi-Trolley Sync Feature

Multi-trolley configured Vector Elite systems consist of multiple trolleys and computers on the same track. Each computer runs the Vector Elite software application, which includes the patient database, and is paired to a specific trolley. The computers are linked through a WiFi router.

The Sync feature synchronizes the patient databases from multiple computers, so the user can access a patient file from any of the computers. This also enables any patient to be trained and have data stored to their patient files using any of the available Vector Elite trolleys. The databases will automatically sync multiple times throughout the day. It is recommended that at the end of the day, on each computer, to transition to the Vector login screen for several minutes prior to exiting the Vector Elite software.

Sync Menu

The Sync menu, found on the Main Menu screen, displays system synchronization status. Use it to view date and time of the last successful and the last failed syncs and the connection status. The user can use the Sync menu to manually sync the patient databases.

To Manually Sync the Patient Databases:

1. Start with one of the computers. From the Main Menu screen, press the Sync menu button. See Figure 10-1.



Figure 10-1: Main Menu Screen

2. The Multi-trolley Database Synchronization window will appear.

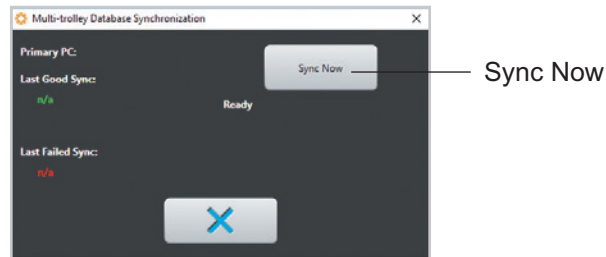

Figure 10-2: Multi-Trolley Database Synchronization Window

3. The window displays how many patient records need to be synced. Press the Sync Now button. See Figure 10-2.
4. From the Main Menu screen on the second computer, press the Sync Menu button.
5. When the Multi-trolley Database Synchronization window appears, press the Sync Now button.
6. Go back to the first computer, and press the Sync Now button. Confirm that the window states "Syncing with primary database." See Figure 10-3.
7. Go back to the second computer and press the Sync Now button. Confirm that the window states "Syncing with primary database".
8. Once the computers have finished the manual sync process, the screen will state "Ready". Press the exit (X) button to close the Multi-trolley Database Synchronization window.

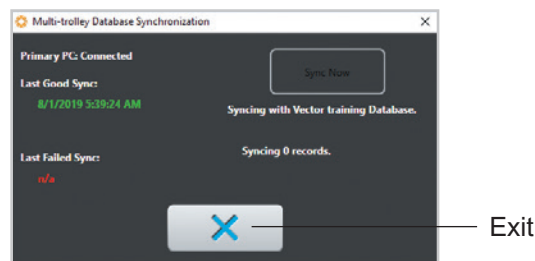

Figure 10-3: Multi-Trolley Database Synchronization Window (Syncing)

Vector Elite Software Administrator Menu

The administrator has a higher level of privileges within the Vector Elite software. Administrator privileges include:

- Managing the patient database (including patient import and export)
- Managing user accounts (create and close accounts)
- Data backup and restore
- Troubleshooting
- System settings

Accessing the Administrator Menu

1. From the Vector login screen enter an administrator user name and password. Press the Enter button to log in. See Figure 11-1.

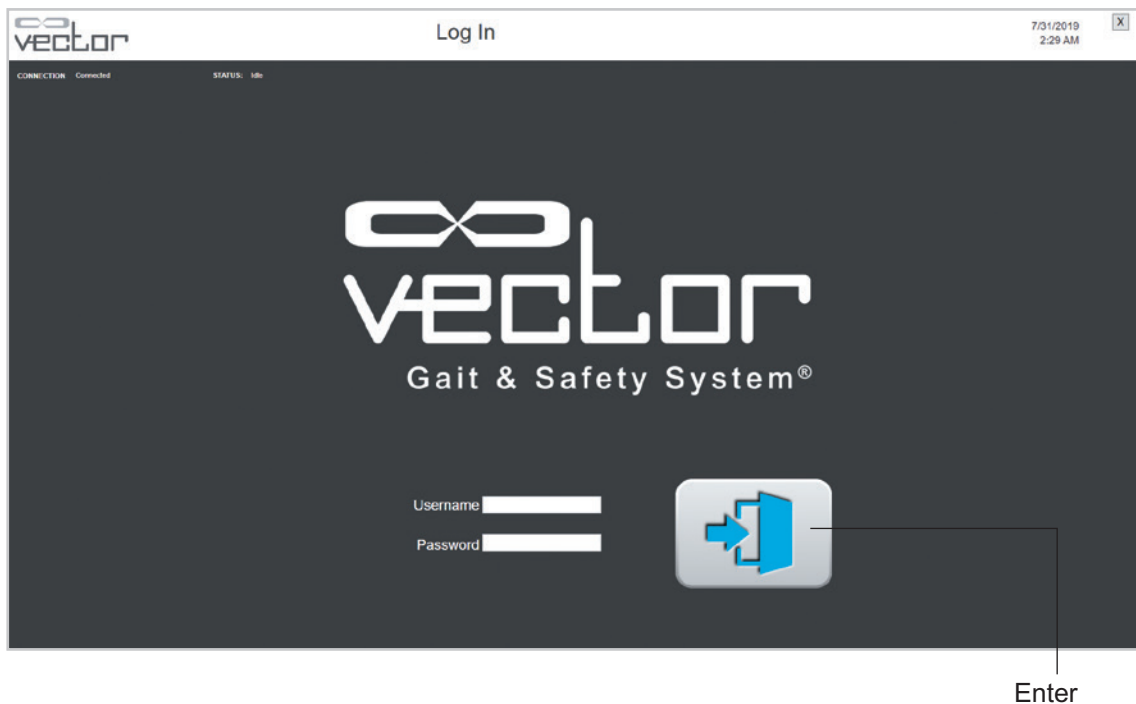

Figure 11-1: Vector Login Screen

2. The Admin Menu screen will open. See Figure 11-2.

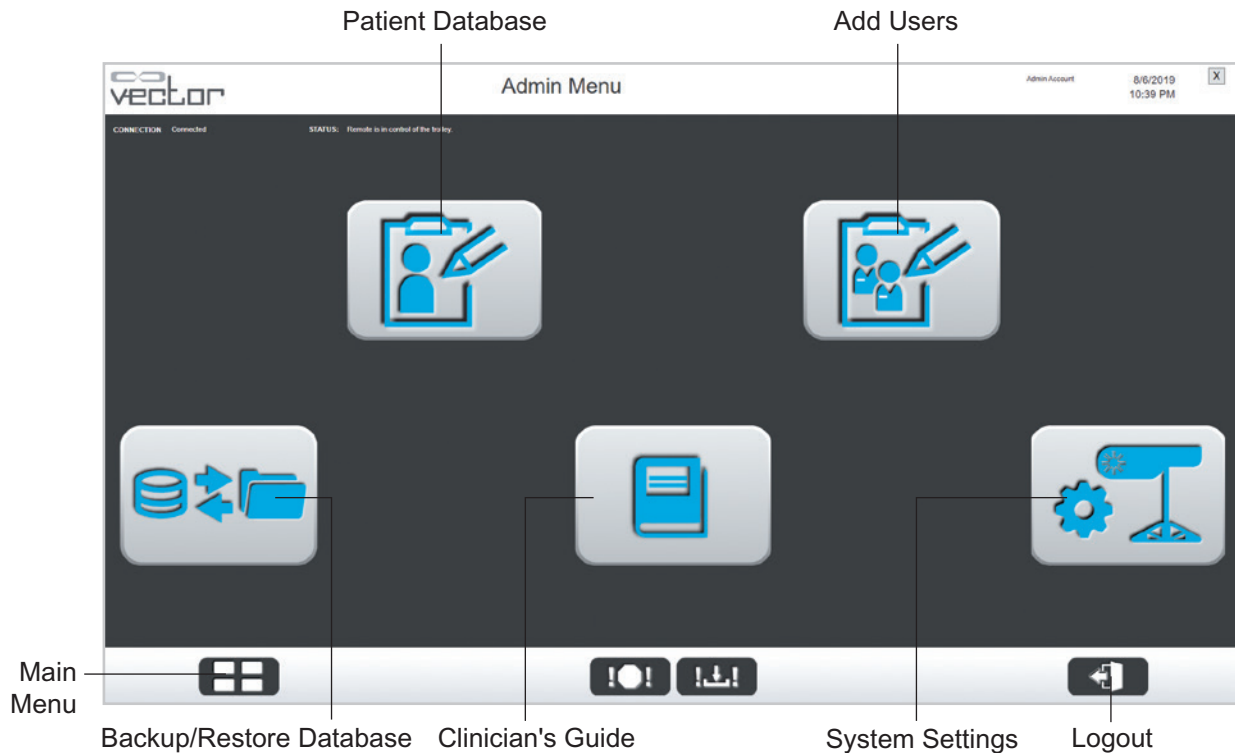

Figure 11-2: Admin Menu Screen

Admin Menu

The Vector Elite Admin Menu screen has five menu options that appear as buttons with descriptive icons. See Figure 11-2.

Admin Menu Options:

- Patient Database menu
- Add Users menu
- Backup/Restore Database menu
- System Settings menu

Patient Database Menu

The Patient Database Menu is used to manage patient records.

1. From the Admin Menu screen, press on the Patient Database button. See Figure 11-2.
2. The Manage Patient Records screen will open. See Figure 11-3.

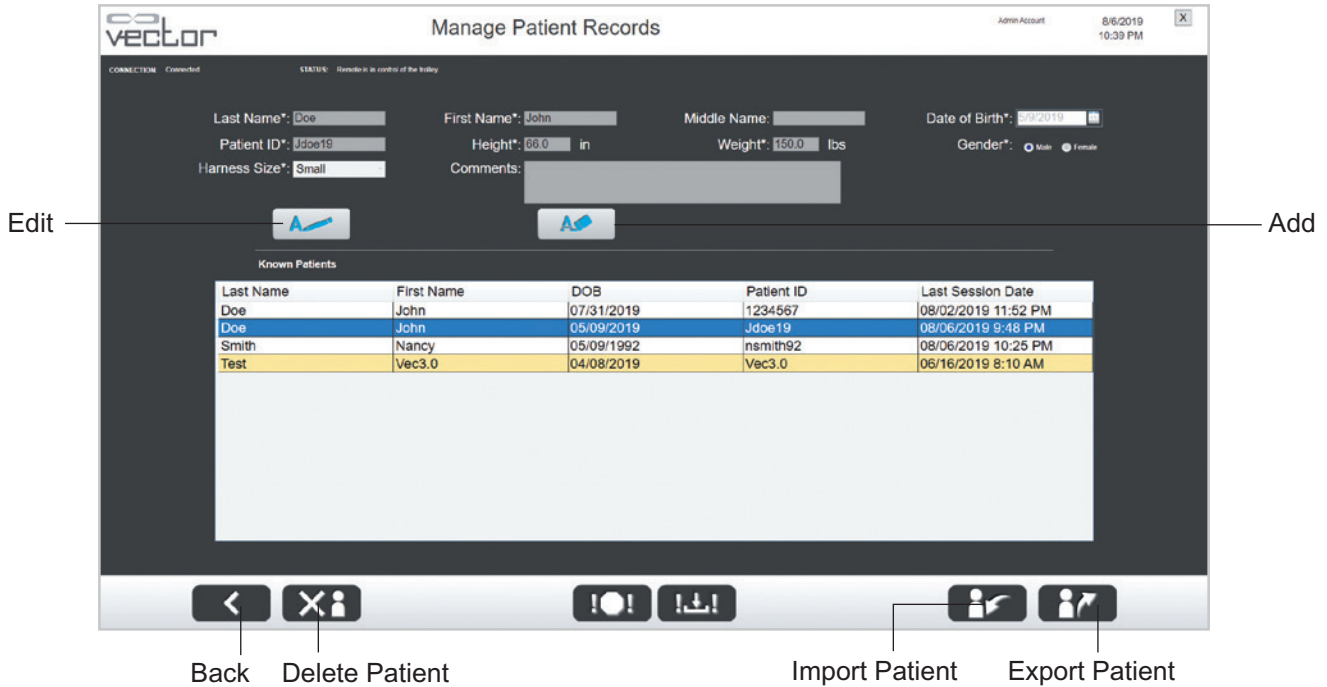

Figure 11-3: Manage Patient Records Screen

Edit a Patient Account

To edit a patient account:

1. Select the desired patient from the Known Patients list and press the Edit button. See Figure 11-3.
2. Revise the patient data fields, verify that revised information is correct, and press the Save button.

Note: The patient ID field cannot be edited.

Create a New Patient Account

To create a new patient account:

1. Press the Add button. See Figure 11-3.
2. Fill in the required patient data fields. Required fields are marked with an asterisk (*). Verify that the information is correct.
3. Press the Save button.

Delete a Patient Account

To delete a patient account:

1. Select a patient from the Known Patients list and press the Delete Patient button. See Figure 11-3.
2. A warning dialog window will appear.
3. Press the check (✓) button to delete the patient account.

Import a Patient Account

The Import Patient Account feature is used in facilities that have separate Vector Elite systems (e.g. inpatient/outpatient facilities). This feature is not used for a multi-trolley configured system.

To import a patient account:

1. From the Manage Patient Records screen, press the Import Patient button. See Figure 11-3.
2. An Open File window will appear. Select the desired patient file and press the Open button.
3. The importing window will appear. The patient information and all training data is imported into the system and incorporated into the Known Patients list.
4. Press the check (✓) button when the importing window states "Complete".

Patient Import Conflict

If the patient ID already exists within the Vector Elite system, you will see a Patient Import Conflicts error message.

Existing Patient:

1. If the patient already exists in the Vector Elite system, press the Same Patient button on the Patient Import Conflicts screen.
2. The program automatically imports the data if imported data is newer than existing data

Different Patient:

1. If the importing patient has a Patient ID matching that of an existing patient, but is not the same patient, press the Different Patient button on the Patient Import Conflicts Screen.
2. A new window will ask if the patient data should be imported under a new Patient ID.
3. Press the check (✓) button to confirm that the patient should be imported into the system with a new, automatically created patient ID.

Export a Patient Account

To export a patient account:

1. From the Manage Patient Records screen, press the Export Patient button. See Figure 11-3.
2. A Save As window will appear. Navigate to the desired location, edit the file name, and press the Save button.
3. The exporting window will appear. The patient information and training data will be saved in a file in the selected location.
4. Press the check (✓) button when the exporting window states "Complete".

Note: There is no effect on the patient account, training data, or ability to train on the current Vector Elite system if a patient is exported. The export file is a copy.

5. To return to the Admin Menu screen, press the Back button. See Figure 11-3.

Add Users Menu

The Add User menu allows the administrator to create, edit, and disable user accounts.

1. From the Admin Menu screen, press the Add Users button. See Figure 11-2.
2. The Add Users screen will open. See Figure 11-4.

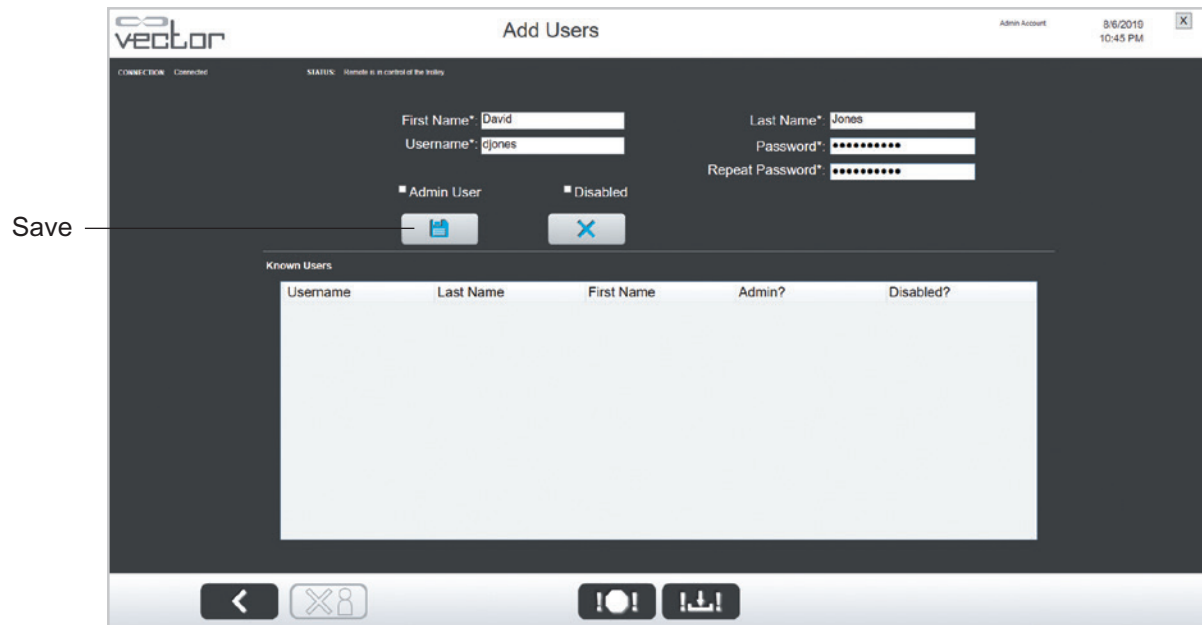

Figure 11-4: Add Users Screen

Create a New User Account

To create a new user account:

1. Enter data in all fields with an asterisk (*). The user name and passwords are set for each user account.
2. To give the new user administrator privileges, check "Admin User."
3. Press the Save button.

Edit a User Account

To edit a user account:

1. Select the user's name from the Known Users list.
2. Press the Edit button. See Figure 11-5.
3. Make revisions to the data fields.
4. Press the Save button.

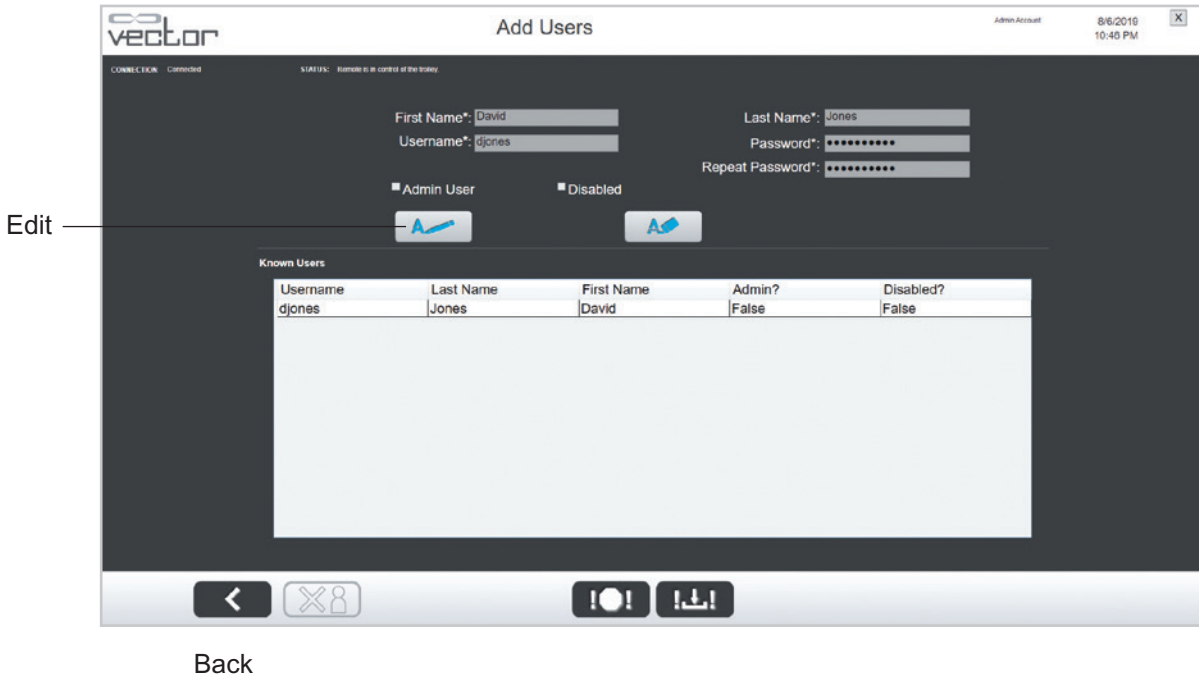

Figure 11-5: Add Users Screen
(Edit User Account)

Disable a User Account

To disable a user account:

1. Select the user's name from the Known Users list.
2. Press the Edit button.
3. Check the box next to "Disabled".
4. Press the Save button.
5. To return the Admin Menu screen, press the Back button. See Figure 11-6.

Backup and Restore Database Menu

The Backup and Restore Database Menu allows the administrator to backup the database to a disc and restore the database to the PC. Every time a user starts the Vector Elite system, a program automatically backs up the database as encrypted files.

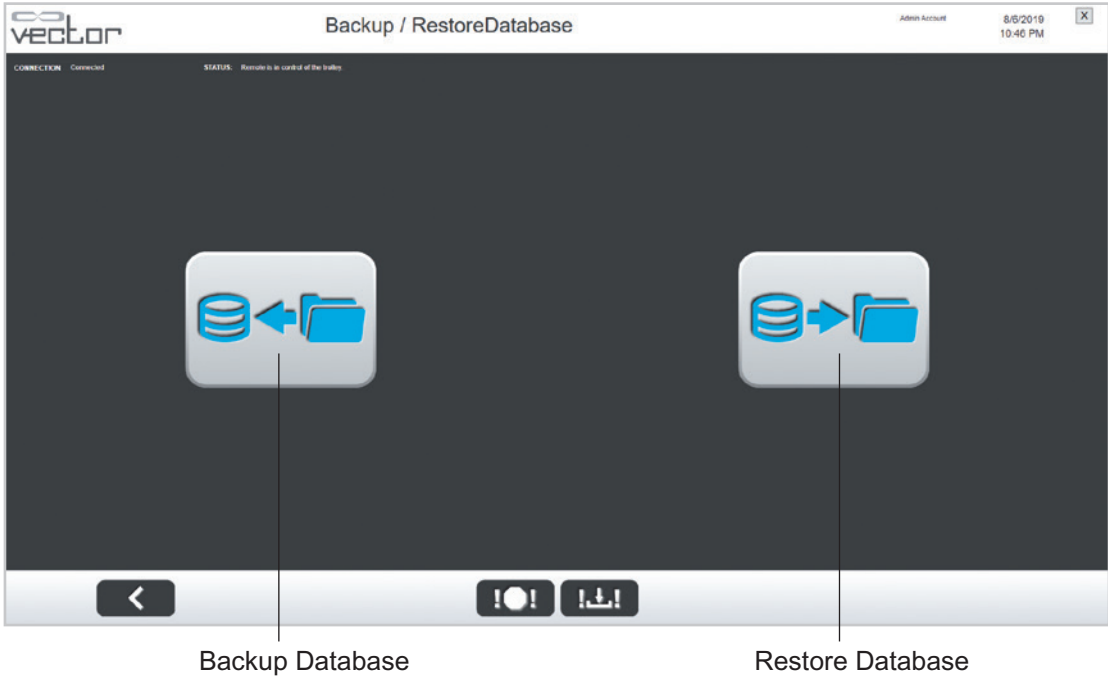

Figure 11-6: Backup/Restore Database Screen

To Backup the System to a Disc:

1. From the Admin Menu screen, press the Backup/Restore Database button. See Figure 11-2.
2. The Backup/Restore Menu screen will open. See Figure 11-6.
3. Press the Backup Database button to backup the system database onto a disc or external hard drive.
4. A Save As window will appear. The content will be save as a ".dat" file. Select the location to store the file, name the file and press the Save button. See Figure 11-7.

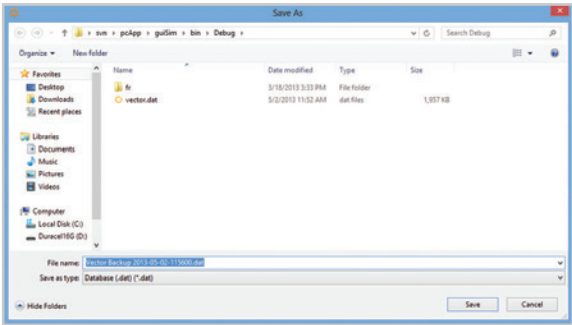

Figure 11-7: Backup Database Save As Window

To Restore the Database to the PC:

1. From the Backup/Restore Menu screen, press the Restore Database button. See Figure 11-6.

- An Open File Window will appear. Find the database file and press the Open button. See Figure 11-8.

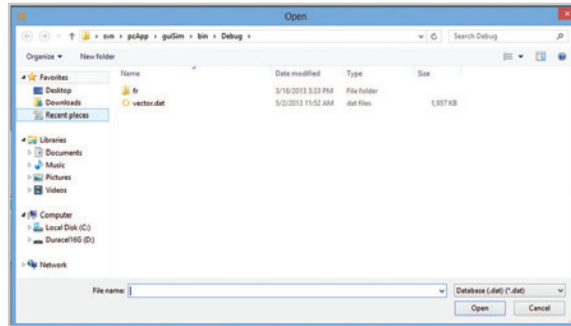

Figure 11-8: Restore Database Open Window

Note: The restore function should only be used in the event of a database error or if advised to do so by Bioness Technical Support.

Troubleshooting Menu

The Troubleshooting menu displays frequently asked troubleshooting questions with solutions.

System Settings Menu

The System Settings menu is used by the administrator to change the language settings, formatting, measurement units, enter clinic information, and activate software modules. The System Settings menu also lists the version of Vector Elite software that is installed. See Figure 11-9.

Tracking Responsiveness

This feature allows the clinician to adjust how responsive the trolley is to patient movements. Depending on patient capability and mobility level, the clinician may increase or decrease the speed at which the trolley responds to patient movement.

High: This high-performance setting is designed to reduce trolley lag as much as possible and keep the angle of the rope vertical. The Vector trolley will be very sensitive to patient movements at this setting.

Normal: This is the ideal setting for patients. Trolley lag is very low, and the trolley provides a high level of control.

Low: This setting may be preferable for very low-level patients. Patients may perceive some backward forces as they walk.

- Navigate to the System Settings Menu.
- To change the Tracking Responsiveness, select Low, Normal, or High. See Figure 11-9.

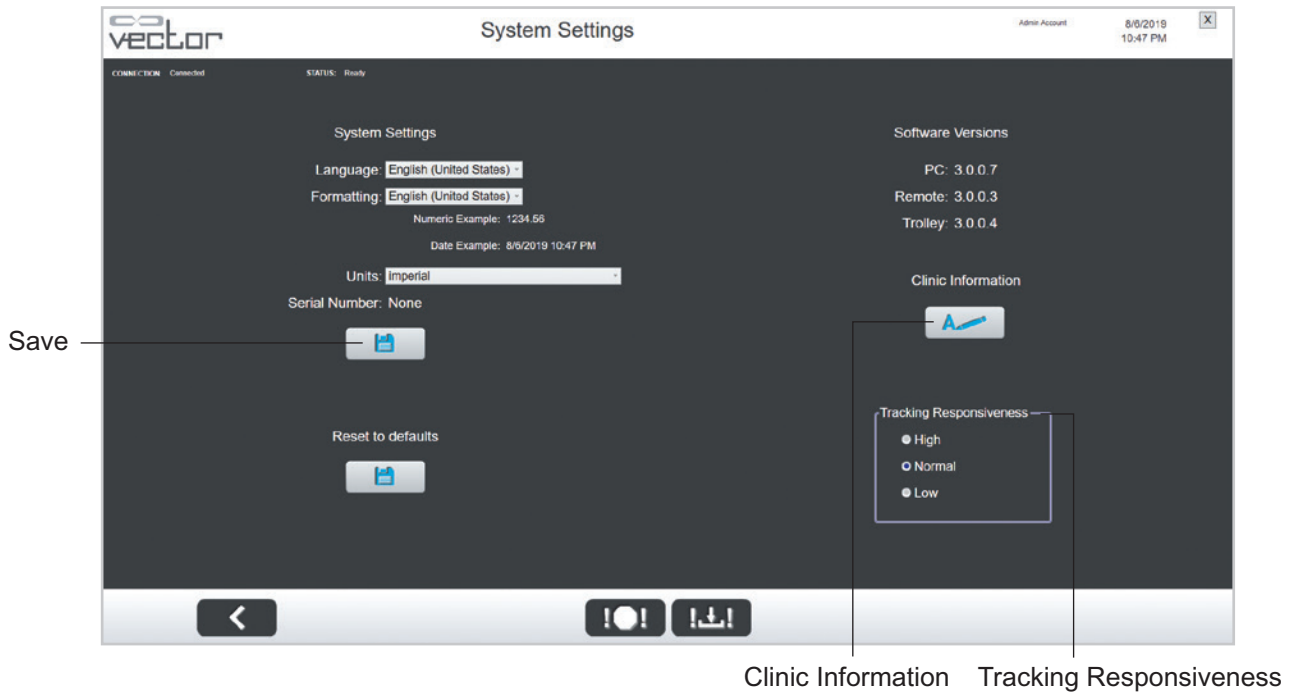

Figure 11-9: System Settings Menu

To change the language settings:

1. From the Admin Menu screen, press the System Settings button.
2. The System Settings Menu will open. See Figure 11-9.
3. Select the language from the drop-down menu.
4. Press the Save button.

To change the formatting settings:

1. Pick the appropriate region from the drop-down menu.
2. A preview of the date, time, and numerical formatting will be displayed.
3. Press the Save button.

To change the unit settings:

1. Select the unit setting from the drop-down menu.
2. Press the Save button.

To enter clinic information:

1. Press the Clinic Information button. See Figure 11-9.
2. The Clinic Information window will appear. See Figure 11-10.



Figure 11-10: Clinic Information Window

3. Enter information in some or all of the fields. Check the box if you wish to include patient identifiers on the Outcome Measures PDF reports.
4. To upload a logo, press the Upload button. The Select a Picture window will appear. Select the file and press the Check Mark button to save. The logo and clinic information will appear on the Outcome Measures PDF reports. Logos should be JPG or PNG files. Recommended size 300 by 140 pixels.
5. On the Clinic Information window, press the Save button.

Troubleshooting

Troubleshooting WiFi Connection Issues

Before attempting to troubleshoot a WiFi connection issue, make sure the Vector Elite trolley is powered on. WiFi connection will not be available until the trolley has fully initialized. Refer to the "Starting the Vector Elite system and Software" chapter in this guide for more information. Additionally make sure that the PC and remote control are within range of the Vector Elite trolley. The PC and remote control need to be within 20 feet (6 meters) of the Vector Elite trolley for proper WiFi connection.

Troubleshooting PC WiFi Connection Issues

For Single Trolley Configured Systems:

1. Press on the wireless network icon  located on the PC status bar.
2. From the list of wireless networks, select the "VectorXXXX" WiFi network. The "XXXX" will be the serial number of the Vector Elite trolley.
3. Recheck the Connect Automatically box and then press on the Connect button. The PC will then connect to the Vector WiFi network.

Note: If the VectorXXXX WiFi network does not appear on the wireless network list, then check to make sure the wireless adapter is properly connected to the PC. The back of the wireless adapter in the USB slot, should be flashing slowly. If it is not, flashing reconnect it to the PC and repeat steps 2-3.

For Multi-Trolley Configured Systems:

1. Press on the wireless network icon  located on the PC status bar.
2. From the list of wireless networks, under the "WiFi" list, select the VectorRouter_MT2G network.
3. Recheck the Connect Automatically box and then press on the Connect button.
4. From the list of wireless networks, under the Vector list, select the VectorXXXX-PC network. XXXX will be the serial number of the Vector Elite trolley.
5. Recheck the Connect Automatically box and then press on the Connect button.

Note: If the VectorRouter_MT2G WiFi network does not appear on the wireless network list, then check to make sure the separate WiFi router is plugged into a power strip and turned on.

Troubleshooting Remote Control WiFi Connection Issues

1. From the remote control home screen, pull the icon bar down to the middle of the screen to display the common settings.
2. Press on the WiFi icon  (hold down for several seconds).
3. From the list of wireless networks, select the VectorXXXX WiFi network.

Elite Trolley Light Indicators

The Vector Elite trolley has a indicator light located on the posterior of the trolley body.

Light Description	Meaning	Solution
Green light	Power is on and the Vector Elite system started properly	N/A
Red light	The Vector Elite trolley has detected a safety relay and goes into safe mode.	The Vector Elite system requires power cycling to reboot: <ul style="list-style-type: none"> • Turn the power off • Turn the power back on • Restart the Vector Elite software application

Table 12-1: Vector Elite Trolley Indicator Lights

Troubleshooting Error Codes

When a trolley error is detected, an Error Code will appear. These errors will cause the Vector Elite trolley to stop the motors and enter safe mode. The Error Codes all show the same message with specific number representing each Error Code. See Figure 12-1. at the end. See Tables 12-2 and 12-3 for descriptions of the Error Code.

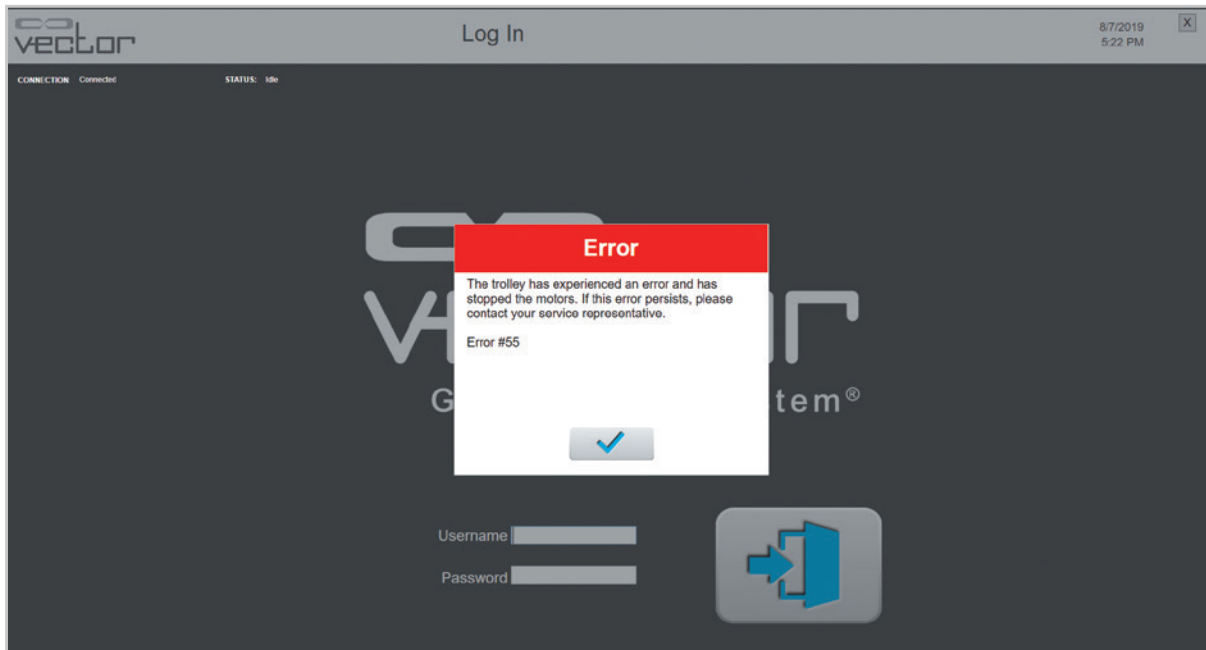

Figure 12-1: Error Message Example

Error Code	Description of Error	Solution
#50	A non-specific trolley error has occurred	<ul style="list-style-type: none"> • Close the error dialog screen • Retry the action <p>If the Error Code is displayed again then the Vector Elite system requires power cycling to reboot:</p> <ul style="list-style-type: none"> • Turn the power off • Turn the power back on • Restart the Vector Elite software application <p>If the Error Code is displayed again after rebooting, stop using the system and call Bioness at 800.211.9136, option 3 (in the United States) or your local distributor (outside of the United States) for troubleshooting assistance.</p>
#55	A non-specific trolley error has occurred	
#81	Trolley firmware error	
#87	Watchdog error	
#92	WiFi interlock error	
#90	Internal networking trolley error	
#98	Trolley servo error	
#99	Winch servo error	
#88	Winch motor controller error	
#89	Trolley motor controller error	

Table 12-2: Error Code Descriptions

Error Code	Description of Error	Solution
#56	A non-specific trolley error	<p>The Vector Elite system requires power cycling to reboot:</p> <ul style="list-style-type: none"> • Turn the power off • Turn the power back on • Restart the Vector Elite software application
#93	Contractor error	
#94	Hardware interlock for the winch has tripped	

Table 12-3: Additional Error Code Descriptions

Service and Maintenance

Routine maintenance is critical for the safety and effectiveness of this device. It is recommended to have a Preventative Maintenance plan for the Vector Elite system as there are consumable parts that may need to be replaced annually (ex. rope)

Check the following items before each use of the Vector Elite system:

- Inspect the Support Rope. If the rope is worn, frayed or damaged call Bioness at 800.211.9136, Option 3 (in the United States) or your local distributor (outside of the United States) for a service appointment to replace the Support Rope.
- Inspect the rope tail. See Figure 13-1. If the rope tail is not visible, the rope knot has been compromised. Call Bioness at 800.211.9136, Option 3 (in the United States) or your local distributor (outside of the United States) for a service appointment
- Inspect the patient harness for tears, material separation and Velcro® degradation.
- Inspect the spreader bar before each use.
- Inspect the carabiners before each use.

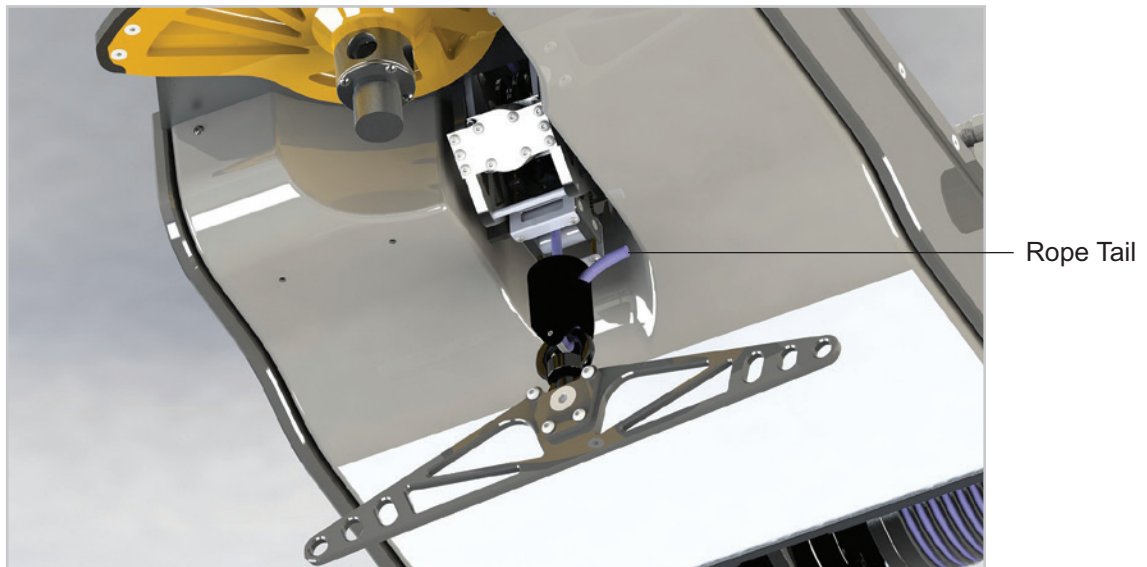

Figure 13-1: Rope Tail

Check the following items on a quarterly basis:

- Inspect the mechanical track. Clean debris and/or dirt, using a clean dry cloth.
- Inspect the trolley body, if needed, wipe the trolley body with a clean dry non-abrasive cloth.

⚠ Warning: Make sure the Vector Elite system is powered off at the wall mounted power supply box before wiping the trolley body or mechanical track. Items to be inspected and maintained on an annual basis:

- Visually inspect the Vector Elite trolley wheels for wear.

- Replace the Support Rope connecting the trolley to the spreader bar annually. Call Bioness 800.211.9136, Option 3 (in the United States) or your local distributor (outside of the United States) for a service appointment. Only Bioness-approved service technicians can perform this service activity. Extra cost may be associated with Support Rope replacement if Preventative Maintenance plan is not purchased/active.

Cleaning the Patient Harness

Cleaning Instructions:

1. Hand wash the patient harness in cold water.
2. Hang dry (do not place harness in the dryer).
3. Do not iron the patient harness.
4. The patient harness may occasionally put in a washing machine for cleaning. Place the entire patient harness in a mesh washing net and wash in warm water. The water temperature should not exceed 90°F (32°C). Use a mild or moderate disinfecting detergent.

PC Disk Storage Space Maintenance

Check PC disk space once a month. It is recommended that there is at least 50 GB of free space available.

To check the PC for Disk Storage Space:

1. Bring up Windows OS File Explorer by simultaneously pressing the Windows key and E key.
2. Click on the computer icon on the left panel. The right panel will show the disk usage. Verify that there is at least 50 GB available.

To Clear Disk Storage Space on the PC:

If there is less than 50 GB of free disk space available on the PC, data must be deleted to create storage space. The backup folder contains backup copies of working data. Remove files that are older than several months old from the backup folder.

1. Connect an external drive to the PC.
2. Browse to the following location – C:\Desktop\vector\AppData\Local\Bioness\Vector\Backups folder
3. Open the Backups folder and sort the folder based on date by clicking on the "Date modified" column heading.
4. Select the files to back up.
5. Right-click on the selected files and select "Cut" menu item.
6. Browse to the external drive folder, and right-click and select "Paste" menu item.
7. Repeat steps 4-6 for other folders that may have grown, such as .csv exports from the Vector software application.

Technical Specifications

Vector Elite System Technical Specifications	
Trolley dimensions	36 inches (91.4 cm) long, 25 inches (63.5 cm) wide, and 11 inches (27.9 cm) tall
Trolley material	Cover is ABS V0 plastic, base is aluminum grade 60601-T6
Trolley patient weight limit	500 lbs. (227 kgs.)
Support Rope material	8 mm diameter HMPE (high modulus polyethylene)
Spreader bar material	Anodized aluminum
Environmental conditions for operation	Temperature range: 15C to 35C Atmospheric pressure range: up to 80kPa Relative humidity range: 20% to 60%.
Environmental conditions for transport and storage	Temperature range: -25C to 70C Atmospheric pressure range: up to 67kPa Relative humidity range: 5% to 95%
Electrical requirements for single trolley configured system	110/120VAC, 20A, 50/60Hz or 220/240VAC, 10A 50/60Hz dedicated circuit Outlet must be capable of delivering 1.8kW
Electrical requirements for multi-trolley configured system	210/240VAC, 20A, 50/60Hz dedicated circuit Outlet must be capable of delivering 3.0kW

The system consists of mechanical and electronic components. Inadequate handling of those components may cause health hazards. Disposal of the system must comply with local regulations.

Electromagnetic Compatibility (EMC) Information

Guidance and Manufacturer’s Declaration—Electromagnetic Emissions		
The Vector Elite System is a body weight support system designed to accelerate physical rehabilitation of patients with severe gait and/or balance impairment. The system unloads a programmed amount of the patient’s weight thus enabling the patient to practice walking with less than a full body weight.		
Emissions Test	Compliance	Electromagnetic Environment — Guidance
RF emissions CISPR 11	Group 1	The Vector Elite System uses RF energy only for communication. Therefore, its RF emissions are very low and are not likely to cause any interference in nearby electronic equipment.
Harmonic emissions IEC 61000-3-2	Class A	The Vector Elite System is intended to be used in a hospital / Professional Healthcare facility environment.
Voltage fluctuations/flicker emissions IEC 61000-3-3	Complies	

Guidance and Manufacturer’s Declaration— Electromagnetic Immunity for All Equipment and Systems			
The Vector Elite System is intended for use in the electromagnetic environment specified below. The customer or the user of the Vector Elite System should assure that it is used in such an environment.			
Immunity Test	IEC 60601 Test Level	Compliance Level	Electromagnetic Environment— Guidance
Electrical fast transient/burst IEC 61000-4-4	+/-2 kV for power supply lines +/- 1 kV for Input/output lines	+/- 2 kV for power supply lines	Mains power quality should be that of a typical commercial or hospital environment.
Surge IEC 61000-4-5	+/-1 kV line to line +/-2 kV line to earth	+/-1 kV line to line +/-2 kV line to earth	Mains power quality should be that of a typical commercial or hospital environment.

**Guidance and Manufacturer’s Declaration—
Electromagnetic Immunity for All Equipment and Systems**

The Vector Elite System is intended for use in the electromagnetic environment specified below. The customer or the user of the Vector Elite System should assure that it is used in such an environment.

Immunity Test	IEC 60601 Test Level	Compliance Level	Electromagnetic Environment—Guidance
Voltage dips, short interruptions and voltage variations on power supply input lines IEC 61000-4-11	<5% U_T (>95% dip in U_T) for 0.5 cycle 40% U_T (60% dip in U_T) for 5 cycles 70% U_T (30% dip in U_T) for 25 cycles <5% U_T (>95% dip in U_T) for 5 sec	<5% U_T (>95% dip in U_T) for 0.5 cycle 40% U_T (60% dip in U_T) for 5 cycles 70% U_T (30% dip in U_T) for 25 cycles <5% U_T (>95% dip in U_T) for 5 sec	Mains power quality should be that of a typical hospital environment. If the user of the Vector Elite System requires continued operation during power mains interruptions, it is recommended that the equipment be powered from an uninterruptible power supply or a battery.
Power frequency (50/60 Hz) magnetic field IEC 61000-4-8	30 Aa/m	30 A/m	Power frequency magnetic fields should be at levels characteristic of a typical location in a typical commercial or hospital environment.

Note: U_T is the AC mains voltage prior to application of the test level.

Guidance and Manufacturer’s Declaration—Electromagnetic Immunity

The Vector Elite System is intended for use in the electromagnetic environment specified below. The customer or the user of the Vector Elite System should assure that it is used in such an environment.

Immunity Test	IEC 60601 Test Level	Compliance Level	Electromagnetic Environment—Guidance
			Portable and mobile RF communications equipment should be used no closer to any part of the Vector Elite System (trolley, hand-held and PC), than the recommended separation distance calculated from the equation applicable to the frequency of the transmitter.

Guidance and Manufacturer's Declaration—Electromagnetic Immunity

The Vector Elite System is intended for use in the electromagnetic environment specified below. The customer or the user of the Vector Elite System should assure that it is used in such an environment.

Immunity Test	IEC 60601 Test Level	Compliance Level	Electromagnetic Environment—Guidance
Conducted RF IEC 61000-4-6	3 Vrms 150 kHz to 80 MHz 6 Vrms ISM and Amateur Radio Bands	3 Vrms 150 kHz to 80 MHz 6 Vrms ISM and Amateur Radio Bands	Recommended separation distance: $d = 1.2\sqrt{P}$
Radiated RF IEC 61000-4-3	10 V/m 80 MHz to 2.7 GHz Proximity Fields per 60601-1-2 4th edition	$[E_{ref}] = 10$ V/m in 26 MHz to 2.7 GHz Proximity Fields per 60601-1-2 4th edition	Recommended separation distance: $d = 0.4\sqrt{P}$, 80–800 MHz range $d = 0.7\sqrt{P}$, 800-2700 MHz range

NOTE 1: At 80 MHz and 800 MHz, the higher frequency range applies.

NOTE 2: These guidelines may not apply in all situations. Electromagnetic propagation is affected by absorption and reflection from structures, objects, and people.

NOTE 3: P is the maximum output power rating of the transmitter in watts (W) according to the transmitter manufacturer and d is the recommended separation distance in meters (m).

NOTE 4: Field strengths from fixed RF transmitters, as determined by an electromagnetic site survey,^a should be less than the compliance level in each frequency range.^b

NOTE 5: Interference may occur in the vicinity of equipment marked with the following symbol: 

^a Field strengths from fixed transmitters, such as base stations

for radio (cellular/cordless) telephones and land mobile radios, amateur radio, AM and FM radio broadcast, and TV broadcast cannot be predicted theoretically with accuracy. To assess the electromagnetic environment due to fixed RF transmitters, an electromagnetic site survey should be considered. If the measured field strength in the location in which the Vector Elite system is used exceeds the applicable RF compliance level above, the Vector Elite system should be observed to verify normal operation. If abnormal performance is observed, additional measures may be necessary, such as re-orienting or relocating the Vector Elite system.

^b Over the frequency range 150 kHz to 80 MHz, field strengths should be less than 3 V/m.

Recommended Separation Distances Between Portable and Mobile RF Communications Equipment and the Vector Elite System			
The Vector Elite System is intended for use in an electromagnetic environment in which radiated RF disturbances are controlled. The customer or the user of the Vector Elite System can help prevent electromagnetic interference by maintaining a minimum distance between portable and mobile RF communications equipment (transmitters) and the Vector Elite System as recommended below, according to the maximum output power of the communications equipment.			
Rated Maximum Output Power of Transmitter (W)	Separation Distance According to Frequency of Transmitter		
	150 kHz to 80 MHz Outside ISM Bands $d = 1.2\sqrt{P}$	80 MHz to 800 MHz $d = 0.4\sqrt{P}$	800 MHz to 2700 MHz $d = 0.7\sqrt{P}$
0.01	0.12 m	0.04 m	0.07 m
0.1	0.38 m	0.13 m	0.22 m
1	1.2 m	0.4 m	0.7 m
10	3.8 m	1.3 m	2.2 m
100	12 m	4 m	7 m

NOTE 1: At 80 MHz and 800 MHz, the higher frequency range applies.

NOTE 2: These guidelines may not apply in all situations. Electromagnetic propagation is affected by absorption and reflection from structures, objects, and people.

For transmitters rated at a maximum output power not listed above, the recommended separation distance d in meters (m) can be determined using the equation applicable to the frequency of the transmitter, where P is the maximum output power rating of the transmitter in watts (W) according to the transmitter manufacturer.

Note: All calculations were made according to tables 204 and 206 of IEC 60601-1-2 for not life-supporting equipment using factors of 3.5 in 0.15–800 MHz and 7 in 800–2500 MHz. There are no requirements for ISM bands in these tables.

Network Safety, Security, and Privacy

The security of Bioness products is an important factor in protecting information and systems from external and internal threats. Therefore, customers must take responsibility for maintaining a secure IT environment that is compliant with general IT standards. Bioness encourages customers to implement the following industry-standard practices:

- Physical Security (e.g. do not allow unauthorized individuals to use the Bioness Vector PC and Hand-held)
- Operational Security (e.g. do not leave sensitive information, such as exported files, on the Bioness Vector PC, and do not leave a logged-in Vector PC unattended, do not connect the PC to the Internet and be careful inserting flash drives to the PC, do not alter the PC or Hand-held software and install unauthorized software on it including Virus scan software)
- Procedural Security (e.g. create awareness of the dangers of social engineering, create separate login credentials for each user for the Bioness Vector, and disable unused accounts)
- Risk Management
- Security Policies
- Contingency Planning

The implementation of security practices may vary by site and include many other technologies, such as firewalls, virus scanning, and anti-spyware software, etc. Although online functionality is disabled on the Bioness Vector PC and Hand-held, a remote possibility remains that the system can be hacked or altered. If such an occurrence is suspected, contact Bioness Technical Support at 800.211.9136, Option 3 (USA & Canada) or your local distributor. Additional information related to security, privacy, and available software upgrade to the system can also be requested from this department.